

ASSEMBLY INSTRUCTIONS FOR

GROUP NO : NORA THB / TFB & NORA F/T RL

DESCRIPTION : TWIN HEADBOARD WITH RGB LED & TWIN FOOTBOARD/SLATS/V.LEGS & TWIN/FULL RAIL

STEP 1

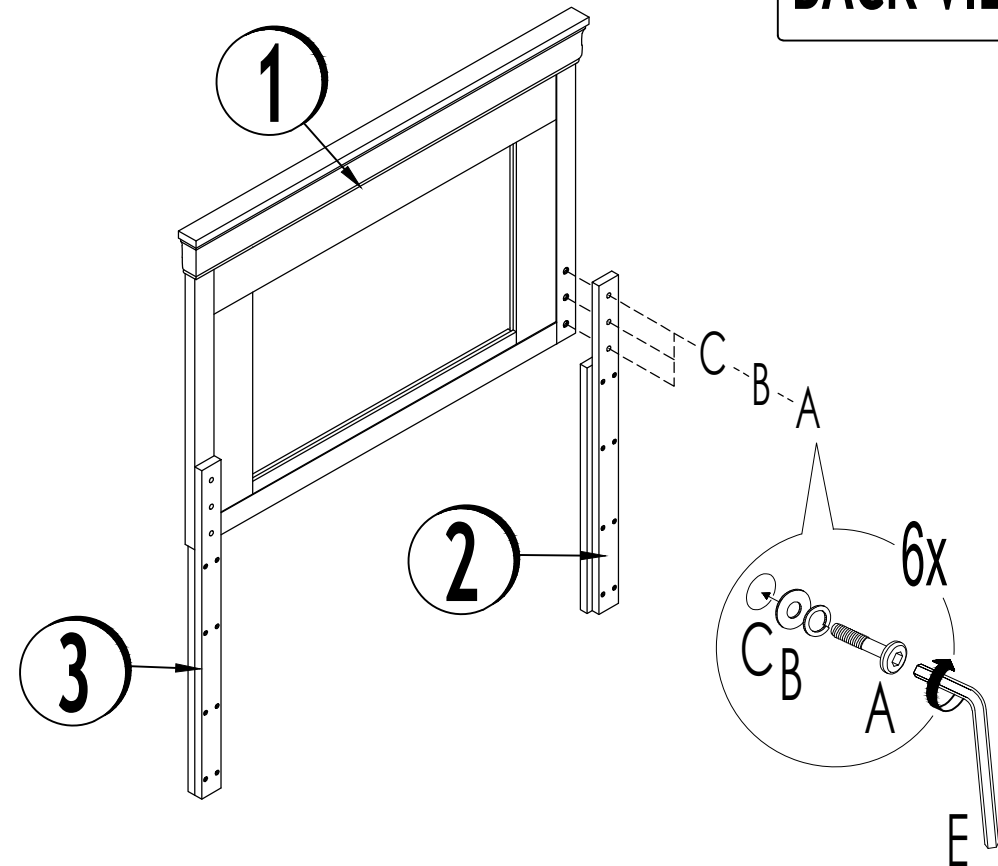

BACK VIEW

STEP 2

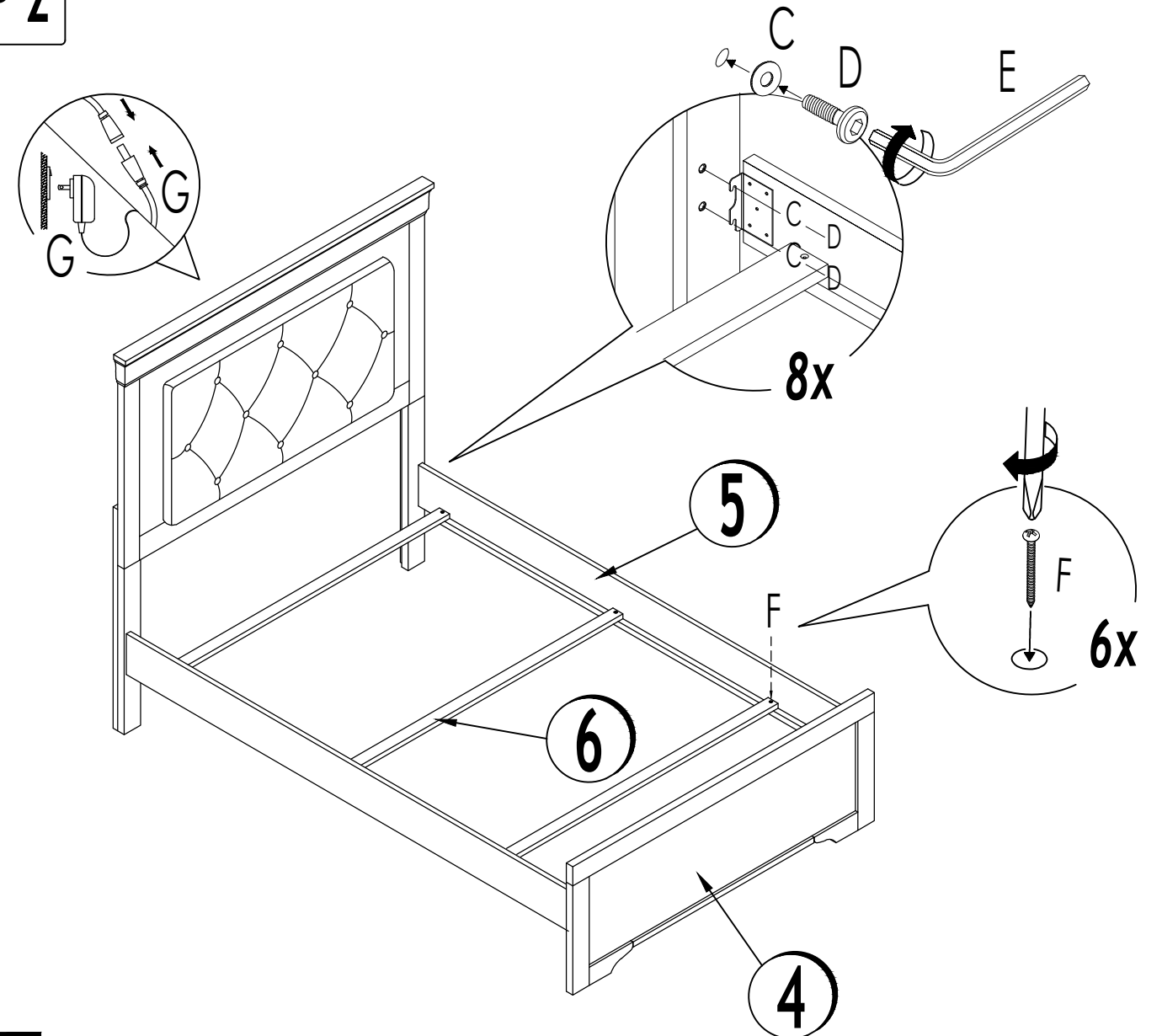

PARTS LIST

HARDWARE LIST

NO	DESCRIPTION	QTY
1	HEADBOARD	1 PC.
2	HEADBOARD LEG (L)	1 PC.
3	HEADBOARD LEG (R)	1 PC.
4	FOOTBOARD	1 PC.
5	SIDE RAIL	2 PCS.
6	SLAT	3 PCS.

NO	DESCRIPTION	SIZE	QTY
A	JCBB	M8 x P1.0 x 40MM	6 PCS.
B	SPRING WASHER	M8	6 PCS.
C	FLAT WASHER	M8 x 18	14 PCS.
D	JCBB	M8 x 20	8 PCS.
E	ALLEN KEY	M5	1 PC.
F	PANHEAD	M4 x 25	6 PCS.
G	ADAPTER		1 PC.
H	REMOTE CONTROL		1 PC.

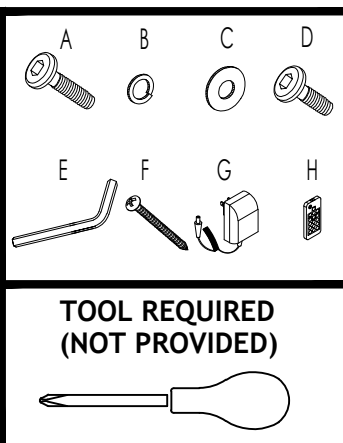

IMPORTANT NOTE :

- * Place all wooden parts on a clean and smooth surface such as a rug or carpet to avoid the parts from being scratched.
- * Check to be sure that you have all parts and hardware.
- * Remove all wrapping materials, including staples & packing straps before you start to assemble.
- * Do not tighten all screws/bolts until all completely assembled.
- * Keep all hardware parts out of reach of children.