

ASSEMBLY INSTRUCTIONS FOR

GROUP NO : NORA QHB/QFB & NORA Q/K RL

DESCRIPTION : QUEEN HEADBOARD WITH RGB LED & QUEEN FOOTBOARD/SLATS/V.LEGS & QUEEN/KING RAIL

STEP 1

BACK VIEW

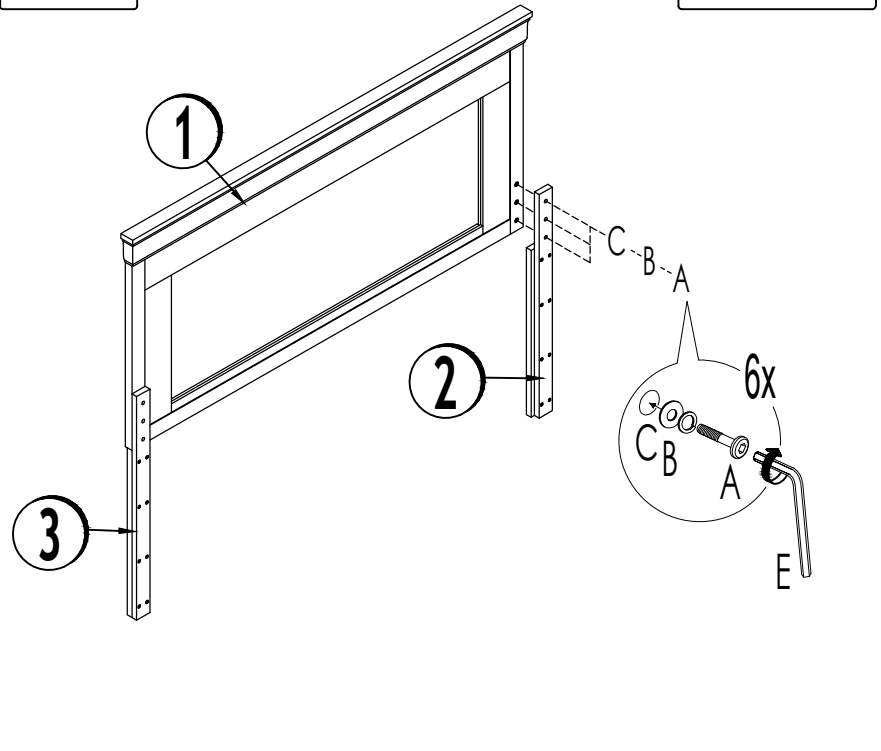

STEP 2

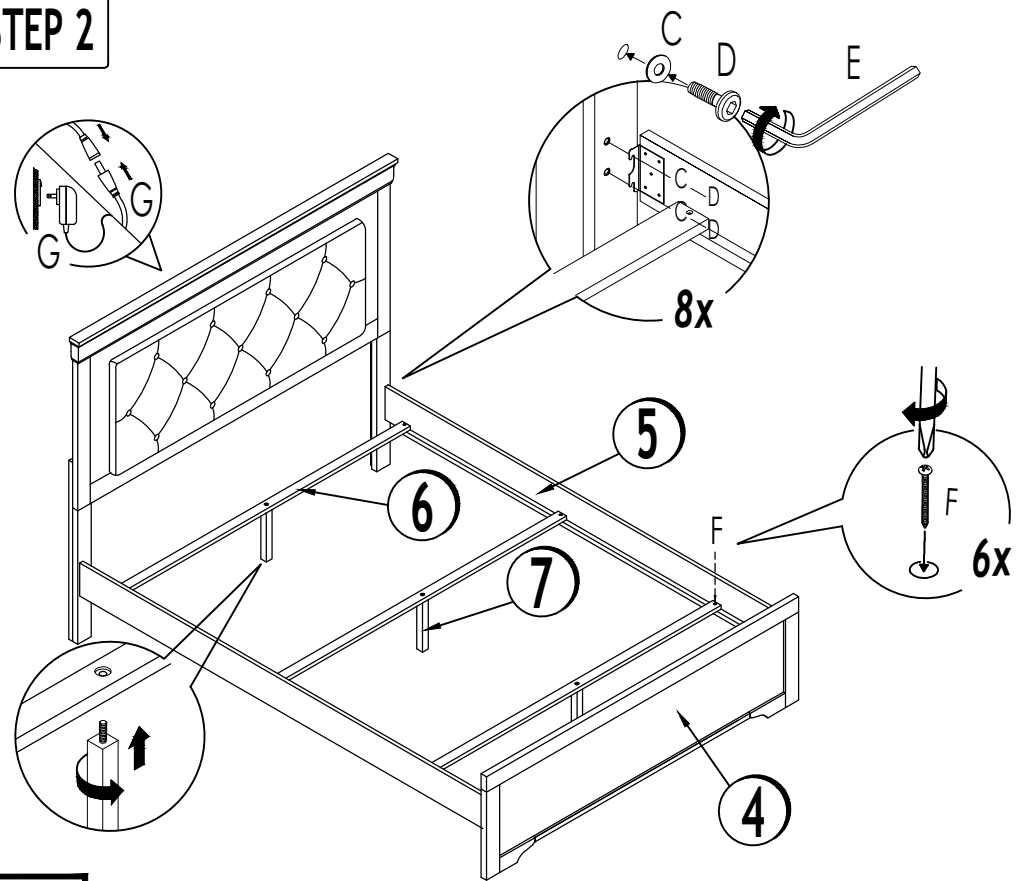

PARTS LIST

HARDWARE LIST

NO.	DESCRIPTION	QTY	NO.	DESCRIPTION	SIZE	QTY
1	HEADBOARD	1 PC.	A	JCBB	M8 x P1.0 x 40MM	6 PCS.
2	HEADBOARD LEG (L)	1 PC.	B	SPRING WASHER	M8	6 PCS.
3	HEADBOARD LEG (R)	1 PC.	C	FLAT WASHER	M8 x 18	14 PCS.
4	FOOTBOARD	1 PC.	D	JCBB	M8 x 20	8 PCS.
5	SIDE RAIL	2 PCS.	E	ALLEN KEY	M5	1 PC.
6	SLAT	3 PCS.	F	PANHEAD	M4 x 25	6 PCS.
7	VERTICAL LEG	3 PCS.	G	ADAPTER		1 PC.
			H	REMOTE CONTROL		1 PC.

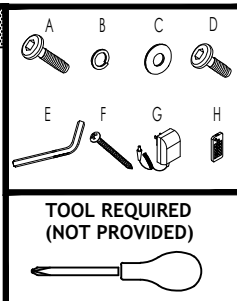

IMPORTANT NOTE :

- * Place all wooden parts on a clean and smooth surface such as a rug or carpet to avoid the parts from being scratched.
- * Check to be sure that you have all parts and hardware.
- * Remove all wrapping materials, including staples & packing straps before you start to assemble.
- * Do not tighten all screws/bolts until all completely assembled.
- * Keep all hardware parts out of reach of children.