

ASSEMBLY INSTRUCTION FOR

GROUP NO.: NANCY KB
DESCRIPTION: KING BED

Thank you for purchasing this quality product. Be sure to check all packing material carefully for small Hardware which may have come loose inside the carton during shipment. Identify and count all hardware and compare with the hardware list below

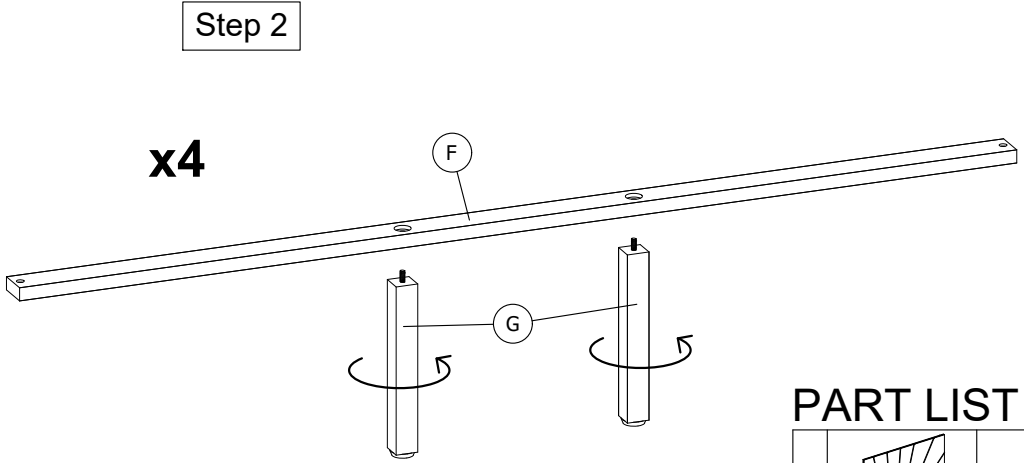
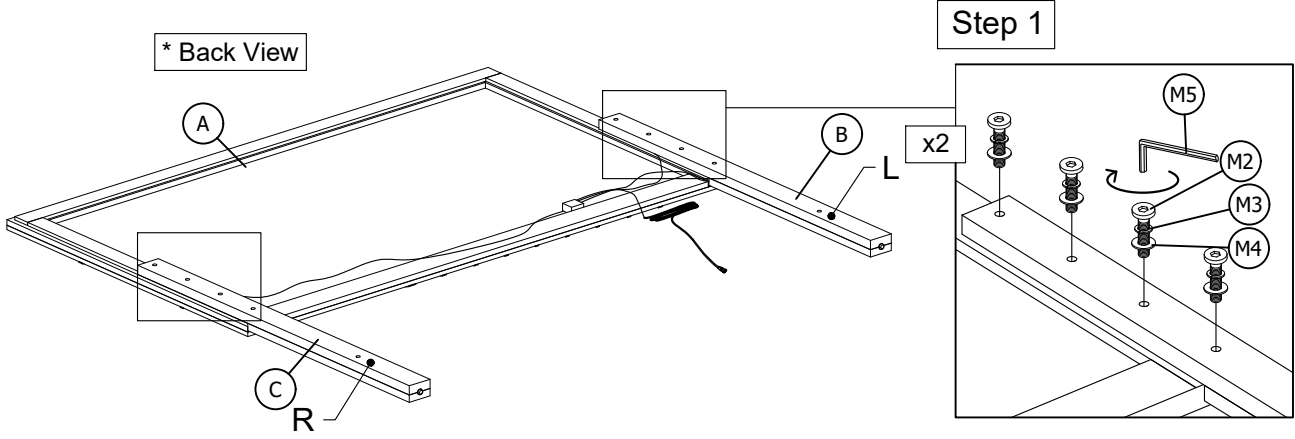

PART LIST

A		HEADBOARD	1PC
B		HEADBOARD LEG LEFT (L)	1PC
C		HEADBOARD LEG RIGHT (R)	1PC
D		FOOTBOARD	1PC
E		SIDE RAIL	2PCS
F		SLAT	4PCS
G		CENTER SUPPORT	8PCS

HARDWARE LIST OF KING BED

M1		BOLT	Ø5/16" x 16MM	8PCS
M2		BOLT	Ø5/16" x 50MM	8PCS
M3		SPRING WASHER	Ø5/16" x 14MM	8PCS
M4		FLAT WASHER	Ø5/16" x 22MM	8PCS
M5		ALLEN KEY	5MM	1PC
M6		CSK C/B SCREW	Ø1/4" x 32MM	8PCS
M7		ADAPTOR	-	1PC

MADE IN MALAYSIA

ASSEMBLY INSTRUCTION FOR GROUP NO.: NANCY KB DESCRIPTION: KING BED

Step 3

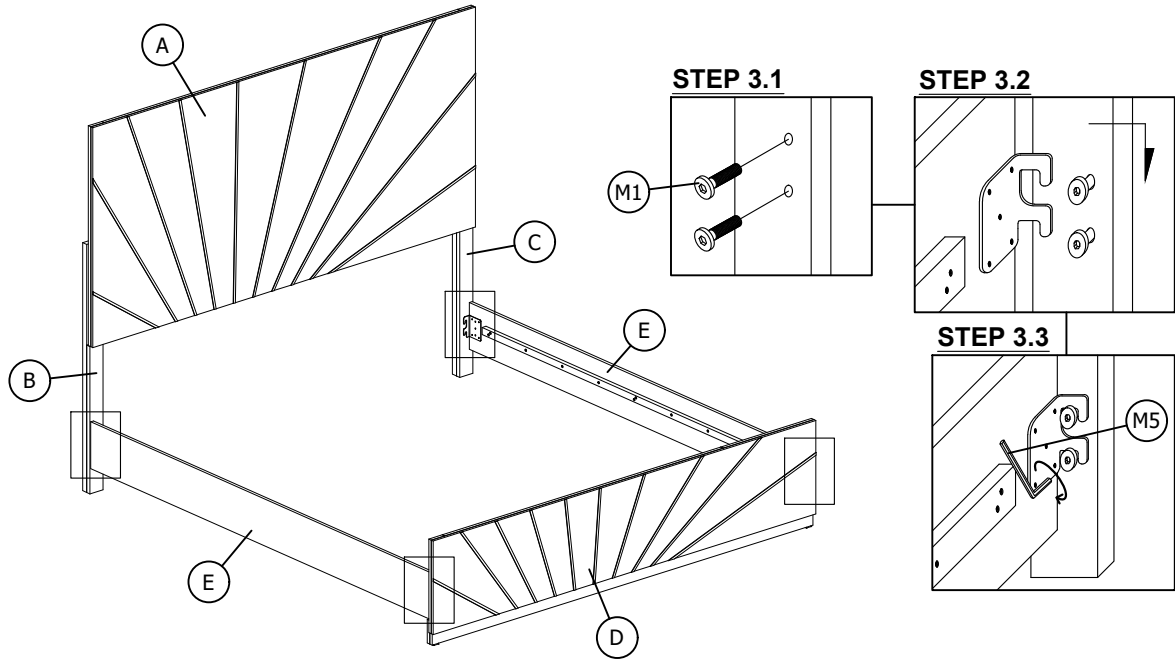

Step 4

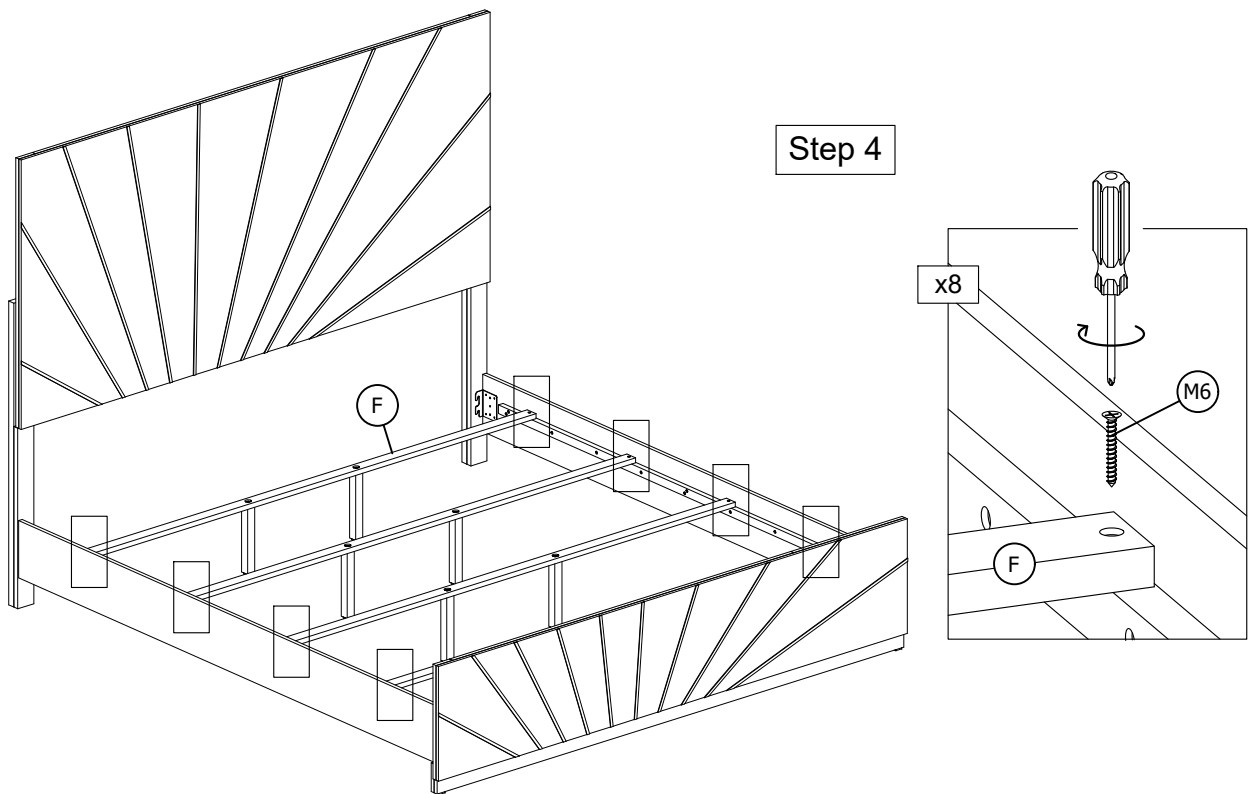

ASSEMBLY INSTRUCTION FOR GROUP NO.: NANCY KB DESCRIPTION: KING BED

Step 5

