

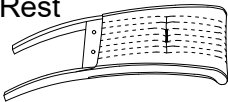







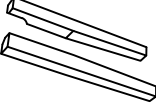

ASSEMBLY INSTRUCTIONS

MODEL : MOZART DC

Item	Description	Qty
1	Back Rest 	1 Pc
2	Seat 	1 Pc
3	Leg R&L 	2 Pcs
4	Stretcher R&L 	2 Pcs

ITEM	HARDWARE LIST	DESCRIPTION	QTY
A	JCBC M6 X 80MM		4PCS
B	JCBC M6 X 60MM		4PCS
C	JCBC M6 X 40MM		2PCS
D	Spring Washer M6		10PCS
E	Flat Washer M6		10PCS
F	Allen Key M4		1PC
G	CSK M4 X 38		4PCS

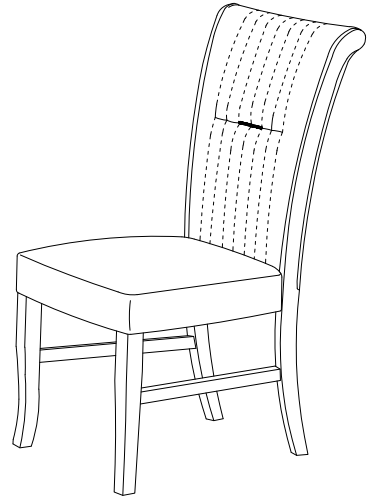

STEP 1

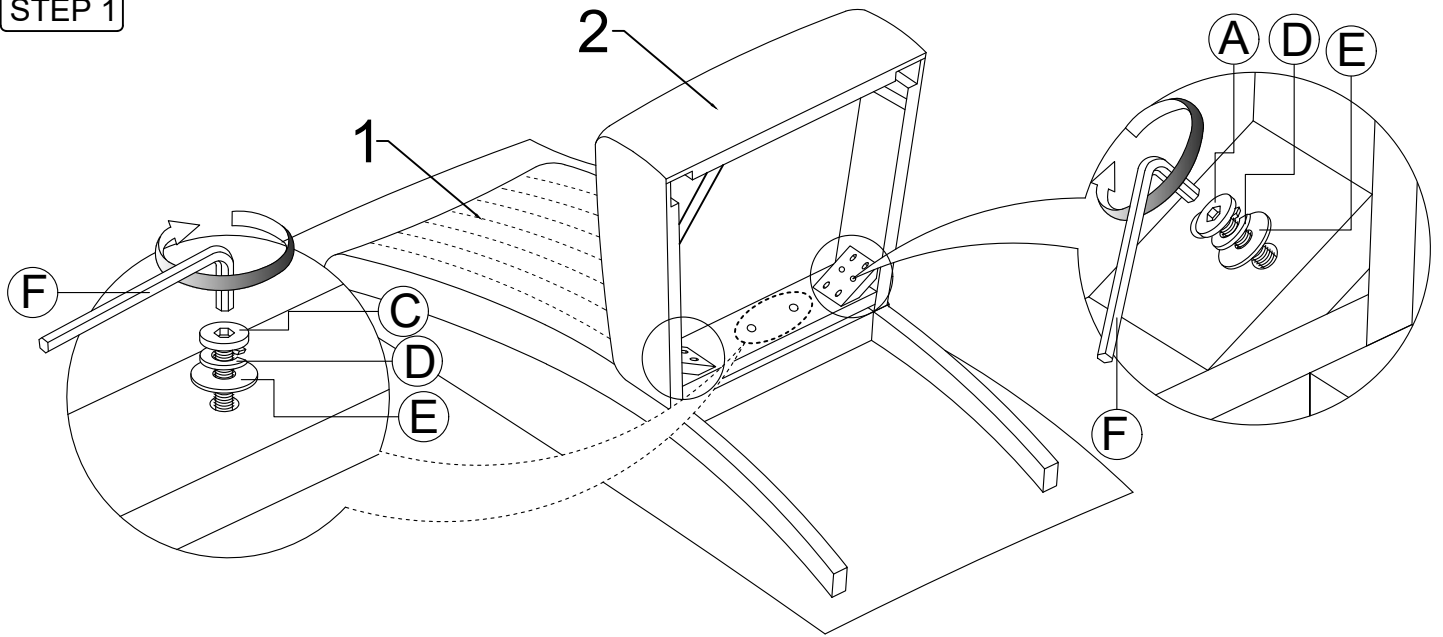

STEP 2

