

ASSEMBLY INSTRUCTIONS

ITEM NUMBER: LEO 5PC

DESCRIPTION: COUNTER HEIGHT SET (1T+4C)





Thanks you for purchasing this quality product.

Please read intructions carefully prior to assembly.



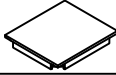

Check carefully for small parts which may have come loose during transportation inside all the boxes.

Remove from boxes and place all parts and components on soft surface such as carpet, blanket or furniture pad. Identify and verify all parts and hardware as specified below.



PART LIST (1 BOX)



NO	DESCRIPTION	OUTLOOK	QT.
1	TABLE TOP		1
2	TABLE LEGS		4
3	CHAIR BACK		4
4	SEAT CUSHION		4
5	CHAIR LEFT LEG		4

PART LIST (1 BOX)

NO	DESCRIPTION	OUTLOOK	QT.
6	CHAIR RIGHT LEG		4
7	LEFT SIDE STRETCHER		4
8	RIGHT SIDE STRETCHER		4
9	FRONT STRETCHER		4

HARDWARE LIST (1 BOX)

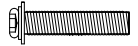
TABLE				
B	BOLT		Ø5/16"x18 x 2-3/8"L	8
E	ALLEN KEY		5MM	1

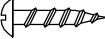
CHAIR				
A	BOLT		Ø5/16"x18 x 3-1/4"L	16
C	BOLT		Ø5/16"x18 x 2-1/4"L	16
D	BOLT		Ø5/16"x18 x 1-1/2"L	8
E	ALLEN KEY		5MM	4
F	SCREW		#4 x 1-3/4"L	24

Tools Required (not provided)

DESCRIPTION	OUTLOOK
PHILLIPS SCREWDRIVER	

Assembly Tips:

- Do not tighten screws and bolts until final steps of the assembly
- This assembly may require additional help (2 person set up)

ASSEMBLY INSTRUCTIONS

ITEM NUMBER: LEO 5PC

DESCRIPTION: COUNTER HEIGHT SET (1T+4C)

STEP 1

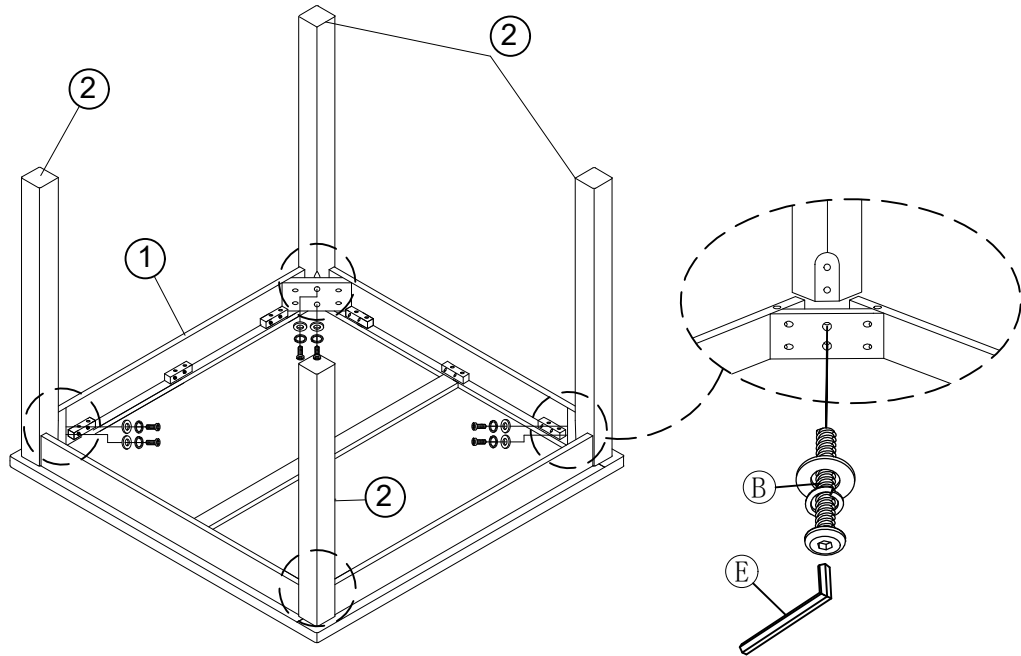

STEP 2

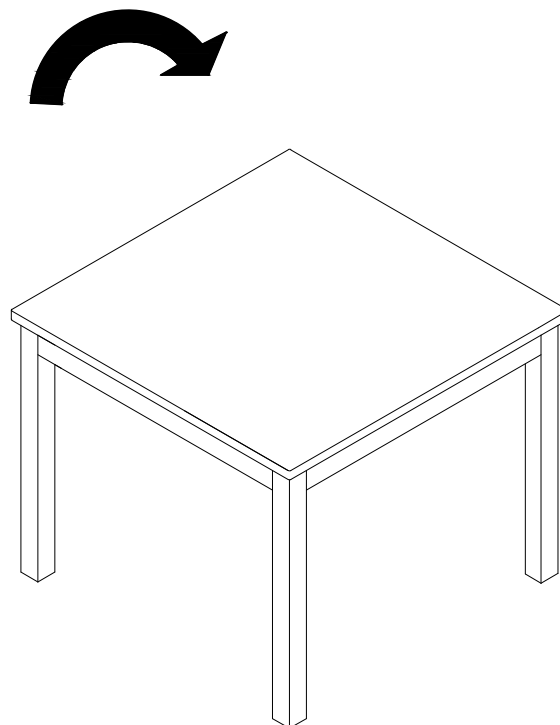

ASSEMBLY INSTRUCTIONS

ITEM NUMBER: LEO 5PC

DESCRIPTION: COUNTER HEIGHT SET (1T+4C)

STEP 3

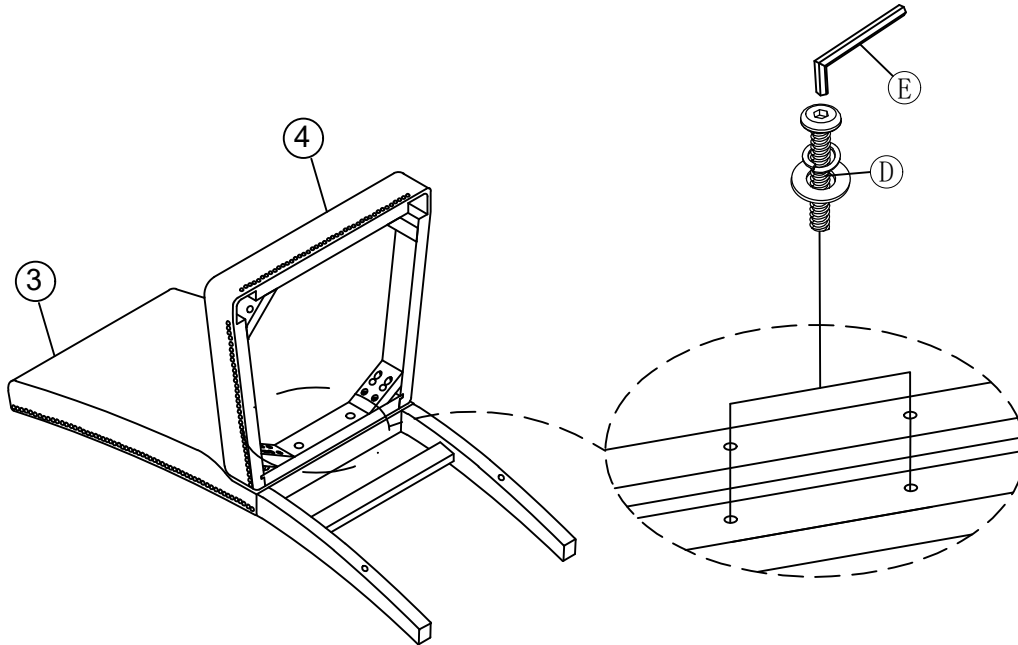

STEP 4

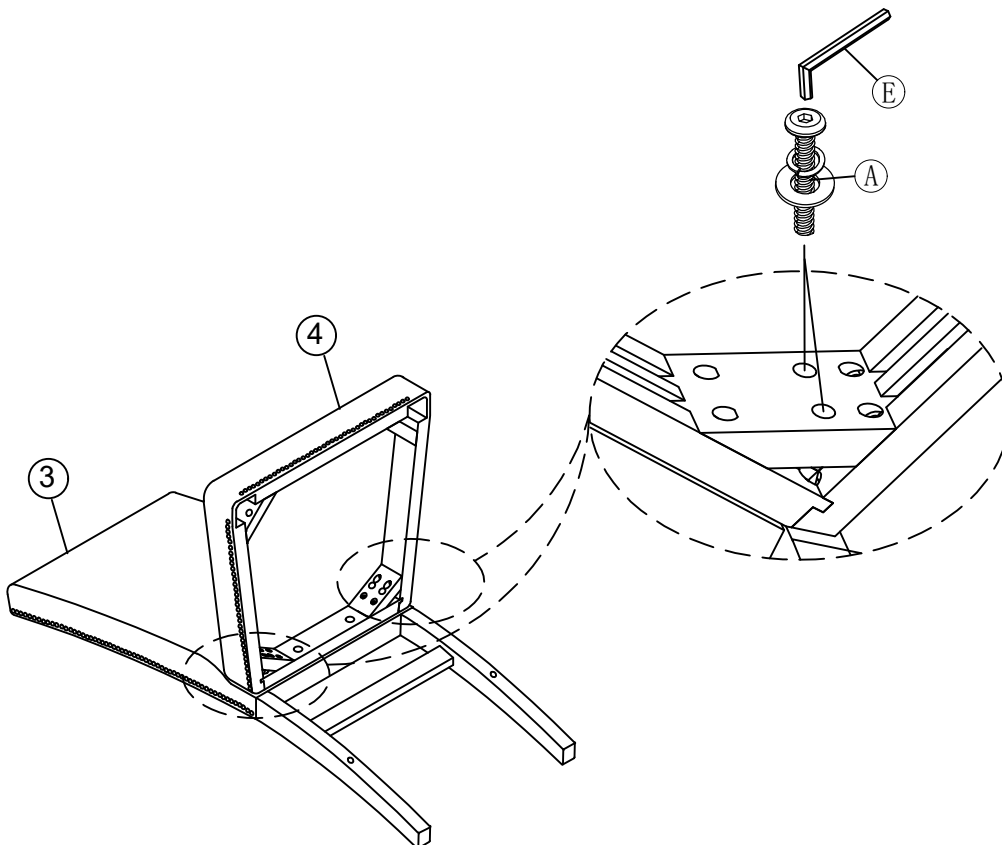

ASSEMBLY INSTRUCTIONS

ITEM NUMBER: LEO

DESCRIPTION: COUNTER HEIGHT SET (1T+4C)

STEP 5

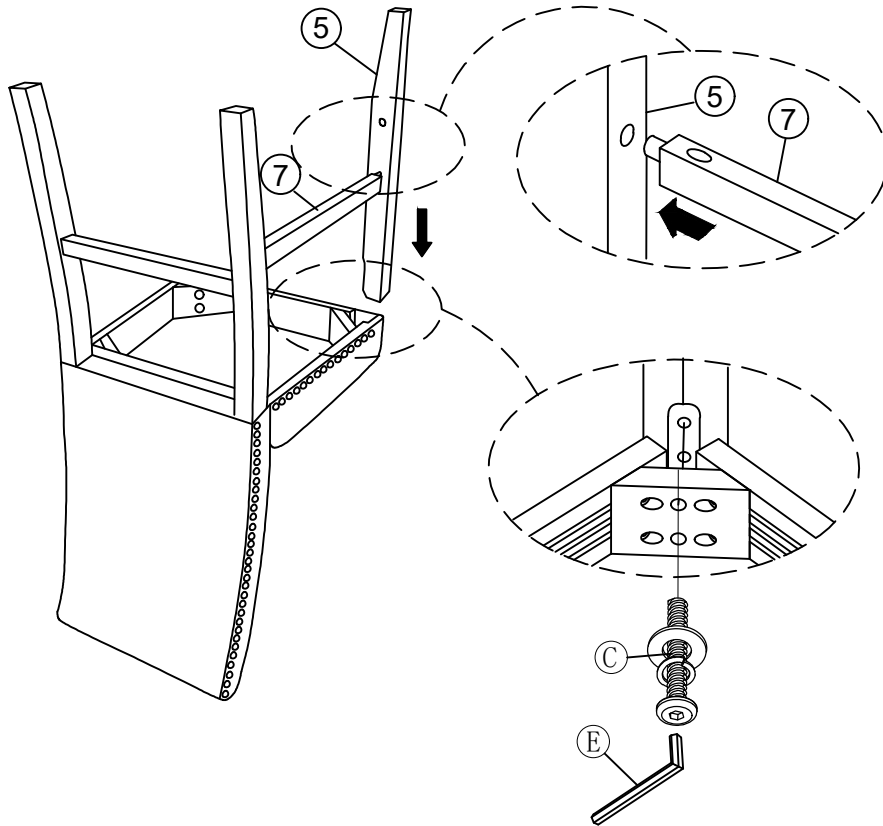

STEP 6

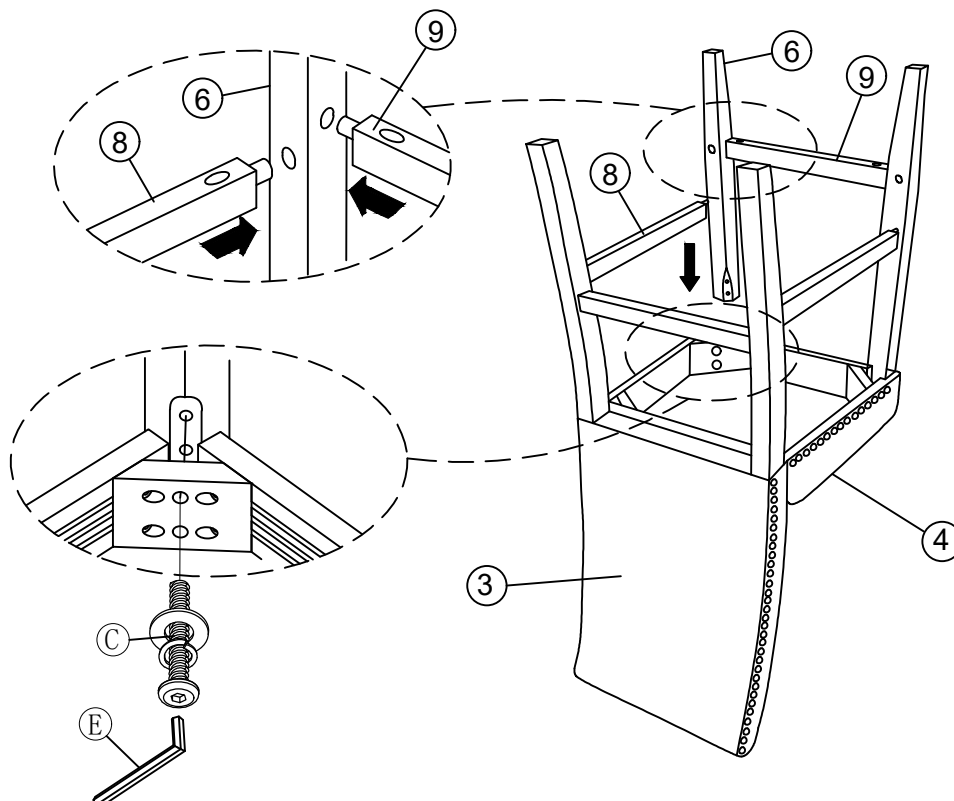

ASSEMBLY INSTRUCTIONS

ITEM NUMBER: LEO 5PC

DESCRIPTION: COUNTER HEIGHT SET (1T+4C)

STEP 7

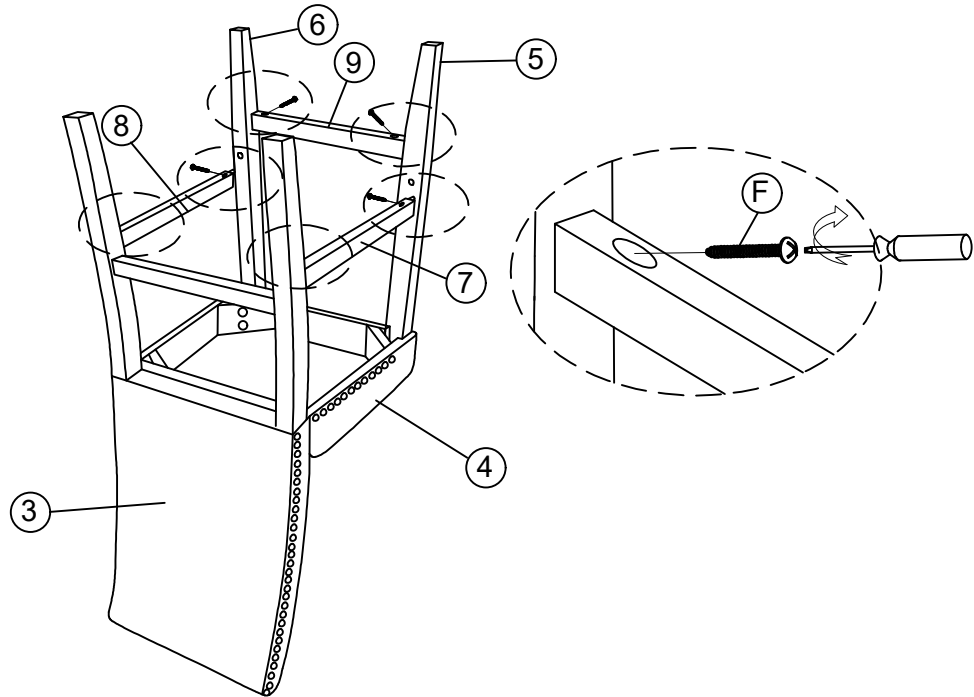

STEP 8

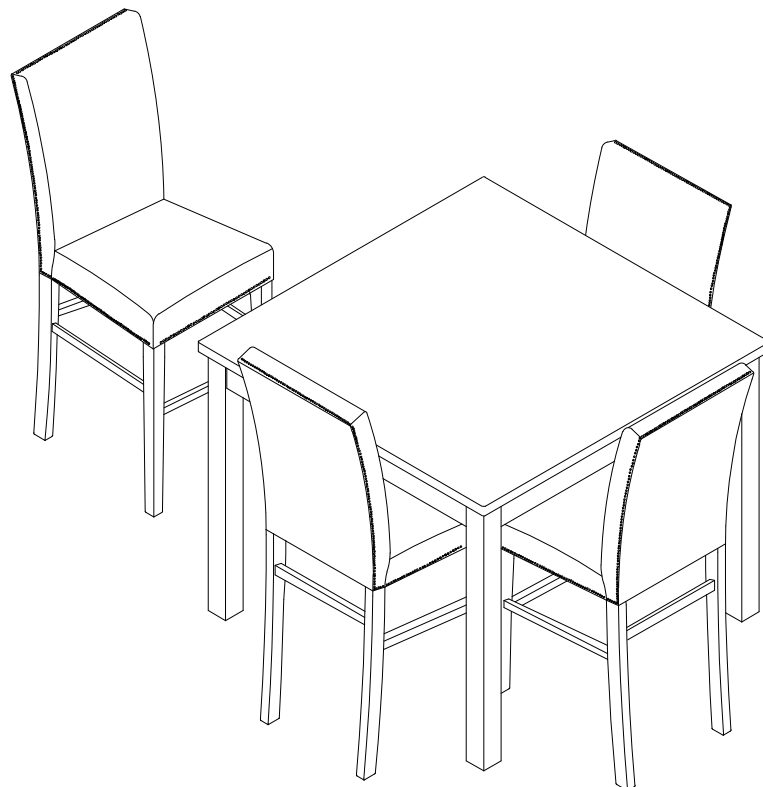

ASSEMBLY IS COMPLETED