

ASSEMBLY INSTRUCTION FOR

GROUP NO.: JULIET WH FB/QB
DESCRIPTION: FULL BED / QUEEN BED

Thank you for purchasing this quality product. Be sure to check all packing material carefully for small Hardware which may have come loose inside the carton during shipment. Identify and count all hardware and compare with the hardware list below

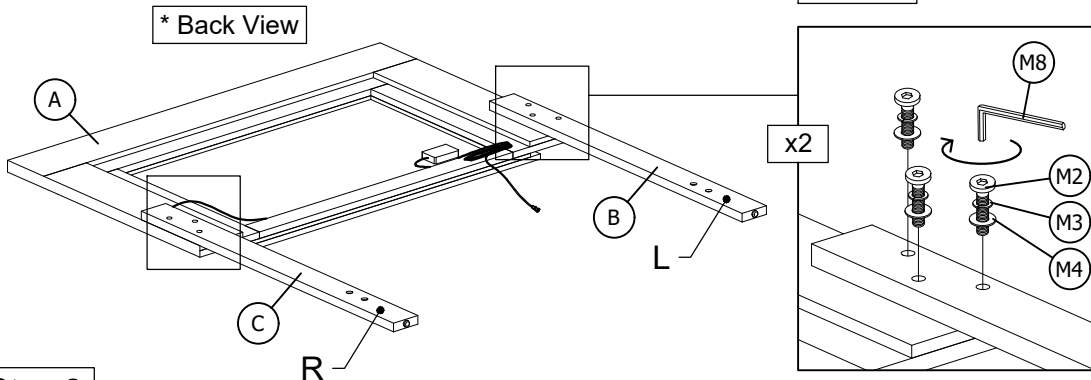





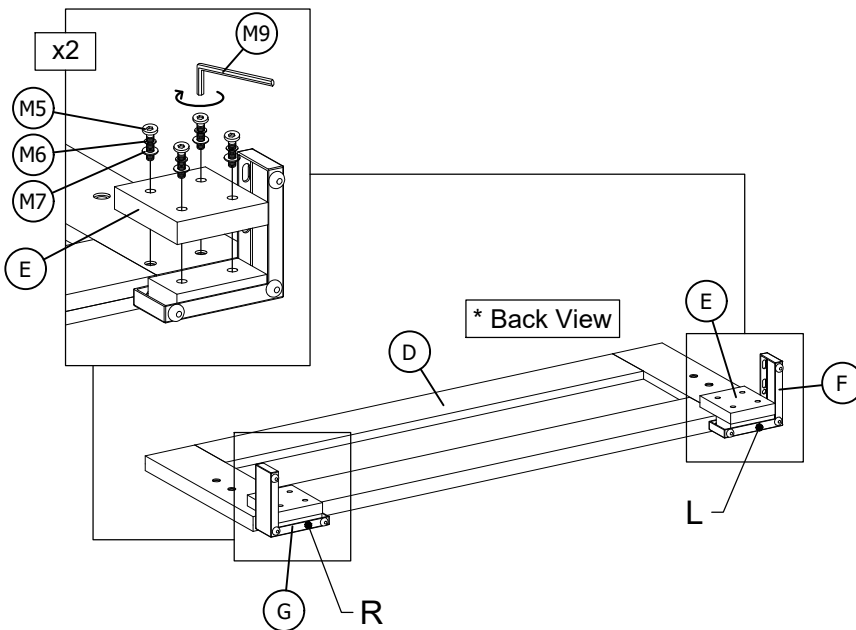

Step 1

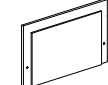

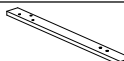

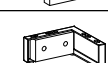
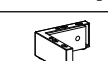







Step 2



PART LIST

Part	Image	Description	Quantity
A		HEADBOARD	1PC
B		HEADBOARD LEG LEFT (L)	1PC
C		HEADBOARD LEG RIGHT (R)	1PC
D		FOOTBOARD	1PC
E		FOOTBOARD SUPPORT	2PCS
F		METAL LEG LEFT (L)	1PC
G		METAL LEG RIGHT (R)	1PC
H		SIDE RAIL	2PCS
I		SLAT	4PCS
J		CENTER SUPPORT	4PCS

HARDWARE LIST OF FULL BED / QUEEN BED

Part	Image	Description	Size	Quantity
M1		BOLT	Ø5/16" x 16MM	8PCS
M2		BOLT	Ø5/16" x 35MM	6PCS
M3		SPRING WASHER	Ø5/16" x 14MM	6PCS
M4		FLAT WASHER	Ø5/16" x 22MM	6PCS
M5		BOLT	Ø1/4" x 35MM	12PCS
M6		SPRING WASHER	Ø1/4" x 13MM	8PCS
M7		FLAT WASHER	Ø1/4" x 19MM	8PCS
M8		ALLEN KEY	5MM	1PC
M9		ALLEN KEY	4MM	1PC
M10		CSK C/B SCREW	Ø1/4" x 32MM	8PCS
M11		ADAPTOR	-	1PC

MADE IN MALAYSIA

ASSEMBLY INSTRUCTION FOR

GROUP NO.: JULIET WH FB/QB
DESCRIPTION: FULL BED / QUEEN BED

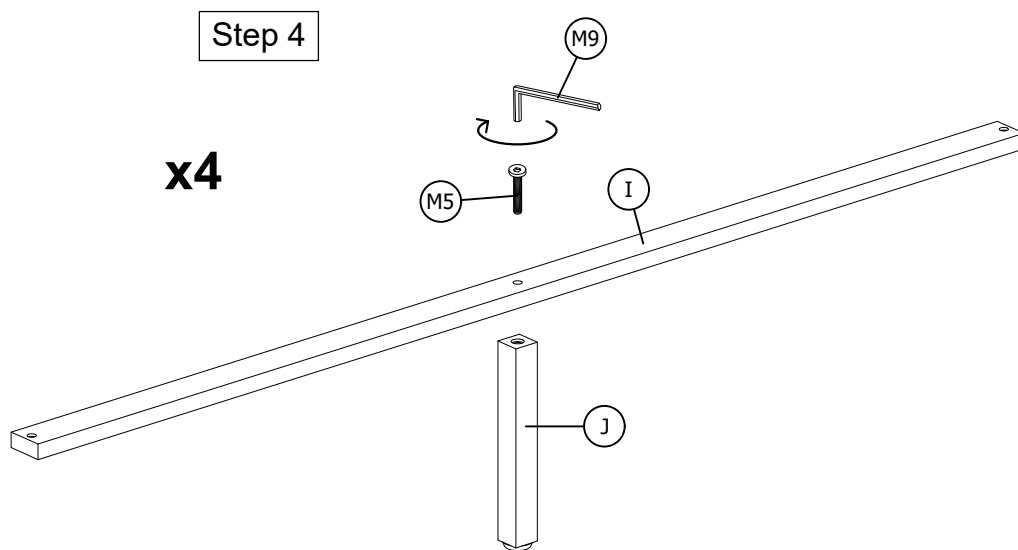
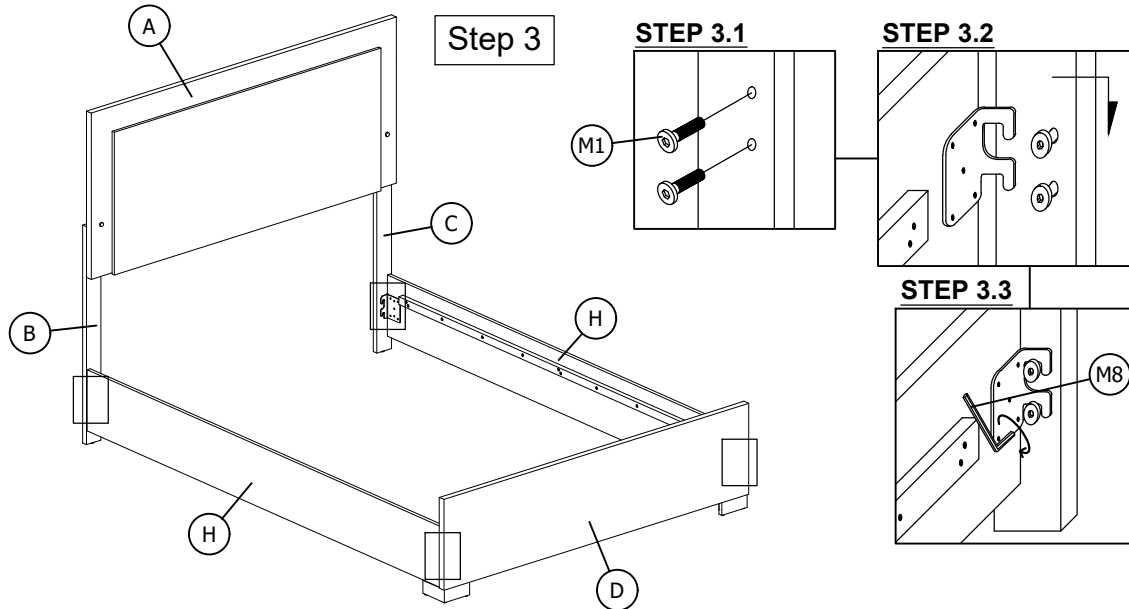

ASSEMBLY INSTRUCTION FOR GROUP NO.: JULIET WH FB/QB DESCRIPTION: FULL BED / QUEEN BED

Step 5

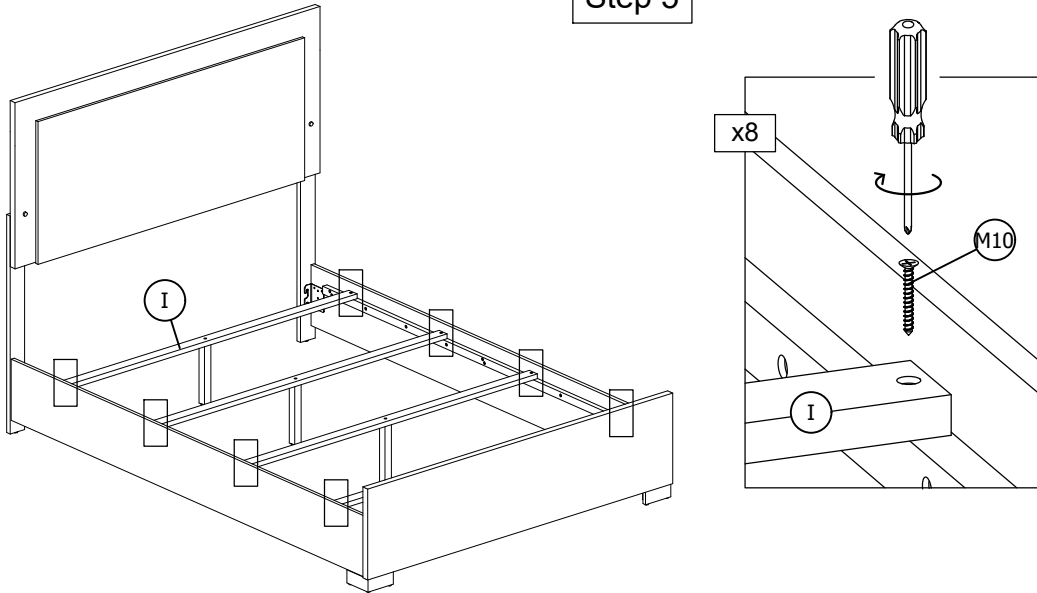

Step 6

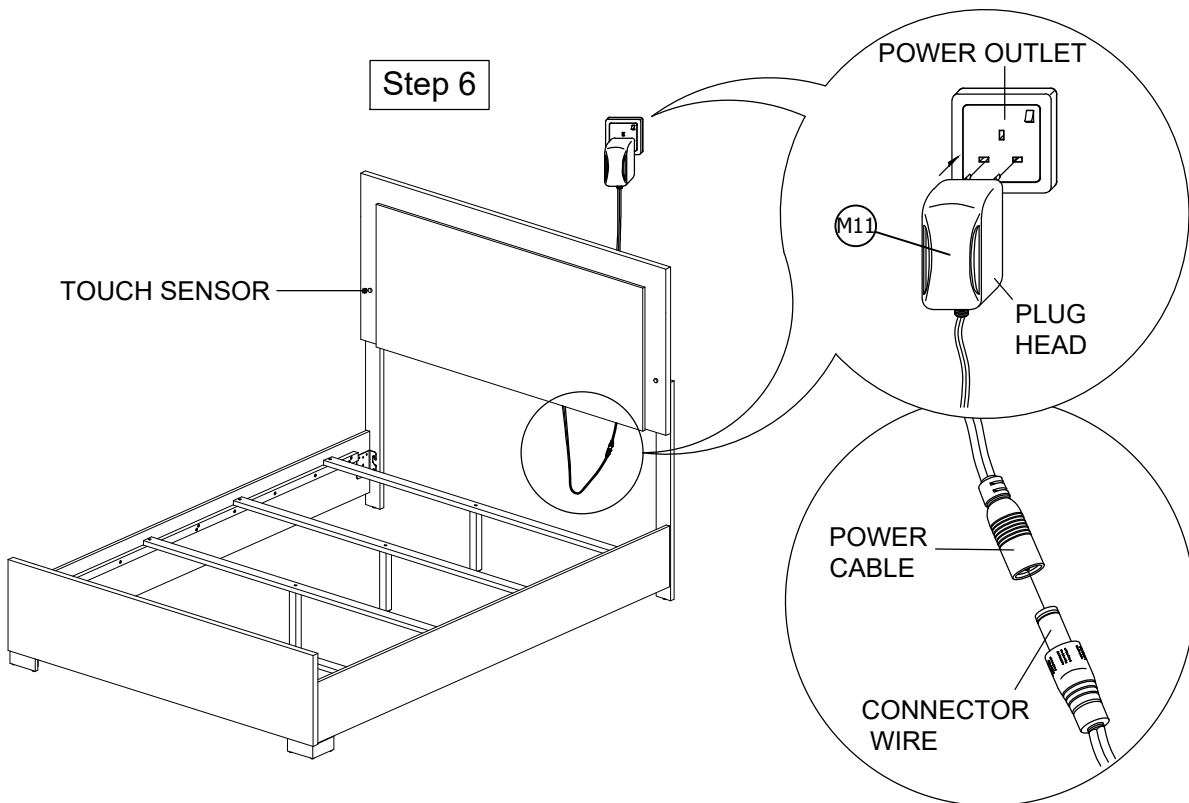



www.FurnitureNearMe.us

ASSEMBLY INSTRUCTION FOR
GROUP NO.: JULIET WH FB/QB
DESCRIPTION: FULL BED / QUEEN BED

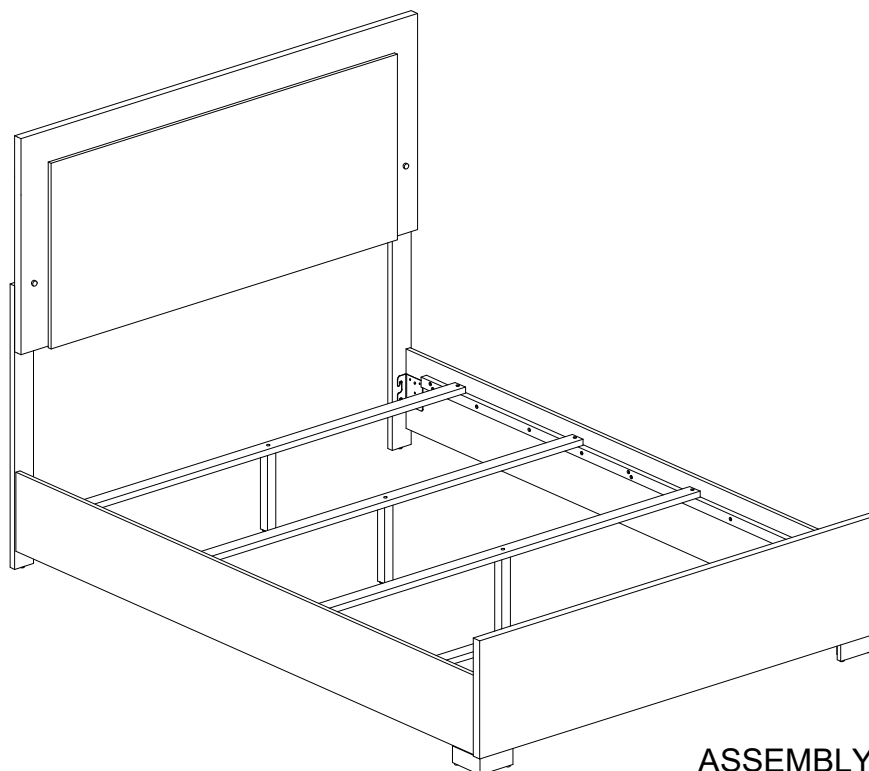

ASSEMBLY
COMPLETED

MADE IN MALAYSIA