

















ASSEMBLY INSTRUCTIONS

ITEM NUMBER: GEMMA-KHB/KFB/Q/K RL

DESCRIPTION: KING BED

Thank you for purchasing this quality product.
Please read instructions carefully prior to assembly.

Check carefully for small parts which may have come loose during transportation inside all the boxes.
Remove from boxes and place all parts and components on soft surface such as carpet, blanket or furniture pad. Identify and verify all parts and hardware as specified below.

Hardware List For Headboard-KHB					Hardware List For Side Rails-RL					Hardware List For Footboard-KFB				
No.	Description	Outlook	Size	Q.ty	No.	Description	Outlook	Size	Q.ty	No.	Description	Outlook	Size	Q.ty
1	Bolt		5/16"x2.1/4"	6	8	Full Thread Bolt		5/16"x4.1/4"	8	12	Bolt		5/16"x4"	2
2	Sping washer		5/16"x1/2"	6	9	Corved Washer		5/16"	8	2	Sping washer		5/16"x1/2"	2
3	Flat washer		5/16"x3/4"	6	10	Nut Washer		5/16"	8	3	Flat washer		5/16"x3/4"	2
4	Bolt		1/4" x 1.1/2"	2	11	Wrench Key		5/16"	1	13	Straight Allen Key		1/4"x4"	1
5	Sping washer		1/4"x1/2"	2						7	Allen Key		1/4"x3"	1
6	Flat washer		1/4" x 3/4"	2						14	Wood Screw		1/6"x1"	8
7	Allen Key		1/4"x3"	1										







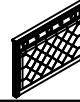

DESCRIPTION	Tools Required (not provided)	Outlook
-------------	-------------------------------	---------

PHILLIPS SCREWDRIVER		
----------------------	--	---

Assembly Tips:

- Place headboard upside down
- Do not tighten screws and bolts until final steps of the assembly
- This assembly may require additional help (2 person set up)

PART LIST

No.	Description	Outlook	Size	Q.ty
A	HEADBOARD		80.5/8" X 3.3/4" X 45"	1
B	HEADBOARD LEFT LEG		32.7/8" X 2.1/2" X 3.1/2"	1
C	HEADBOARD RIGHT LEG		32.7/8" X 2.1/2" X 3.1/2"	1
D	FRONT STRETCHER		78.7/8" x1.1/2" x 2.3/4"	1
E	FOOTBOARD		80.5/8" x 2.5/8" x 24.5/8"	1
F	FOOTBOARD LEG		3"X 3" X 4.1/2"	2
G	SLATS		76.3/4"X 2.3/4" X 3/4"	4
H	SUPPORT LEG		1.1/5" X 1.1/5" X 8.7/8"	8
I	RAILS		82"X 7.7/8" X 4.1/2"	2

ASSEMBLY INSTRUCTIONS

ITEM NUMBER: GEMMA-KHB/KFB/Q/K RL
DESCRIPTION: KING BED

Thank you for purchasing this quality product.

Please read instructions carefully prior to assembly.

Check carefully for small parts which may have come loose during transportation inside all the boxes. Remove from boxes and place all parts and components on soft surface such as carpet, blanket or furniture pad. Identify and verify all parts and hardware as specified below.

STEP 1

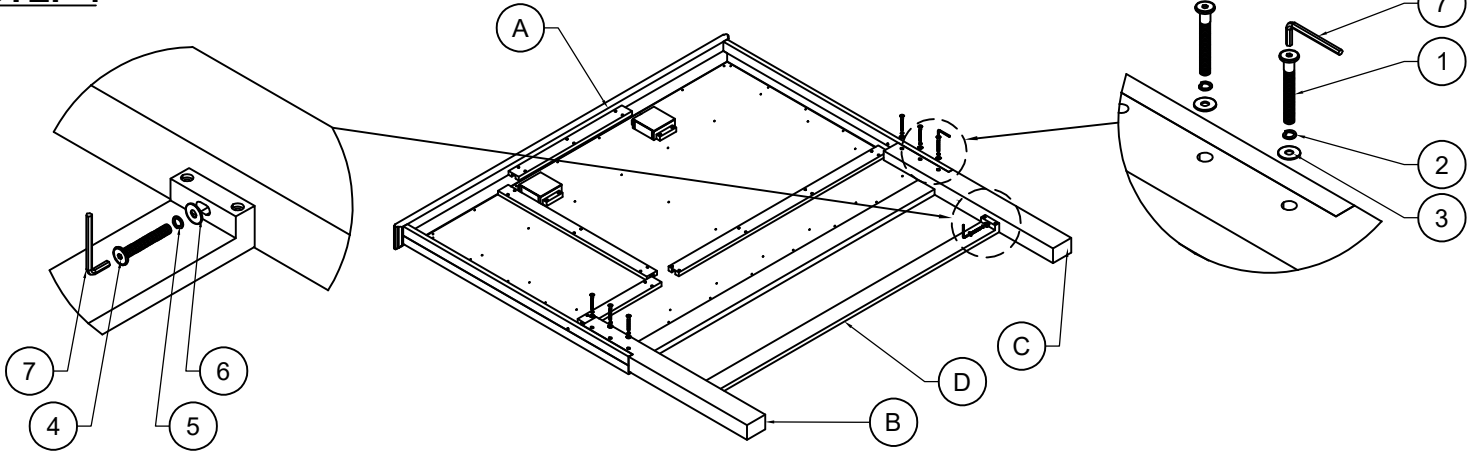

STEP 2

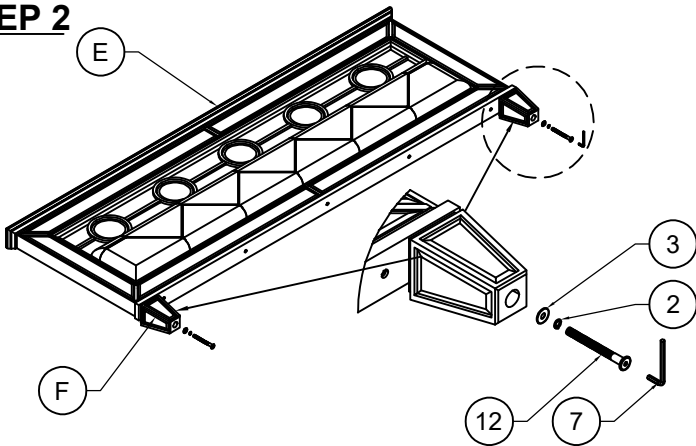

STEP 3

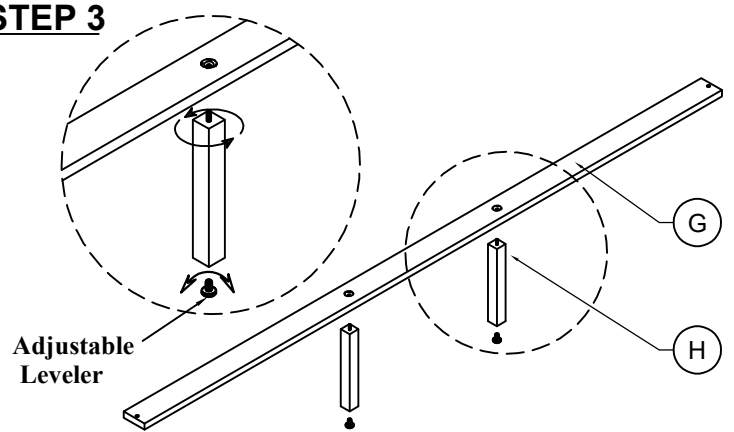

STEP 4

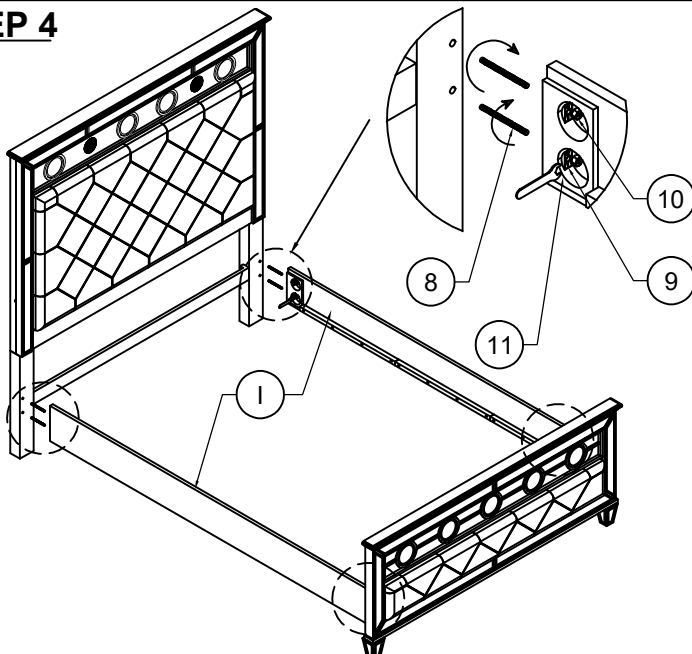

STEP 5

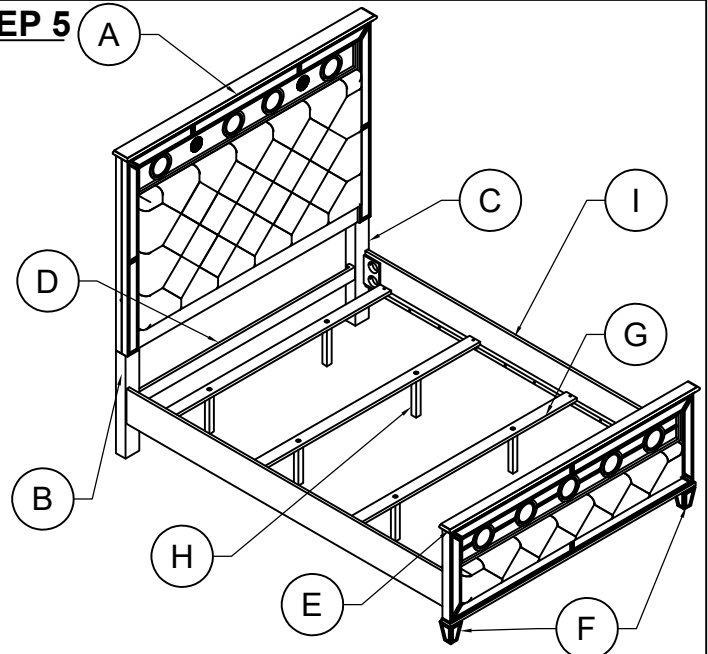

ASSEMBLY INSTRUCTIONS

ITEM NUMBER: GEMMA-KHB/KFB/Q/K RL
DESCRIPTION: KING BED

ADDITIONAL ASSEMBLY INFORMATION

ELECTRICAL CONNECTION DIAGRAM.

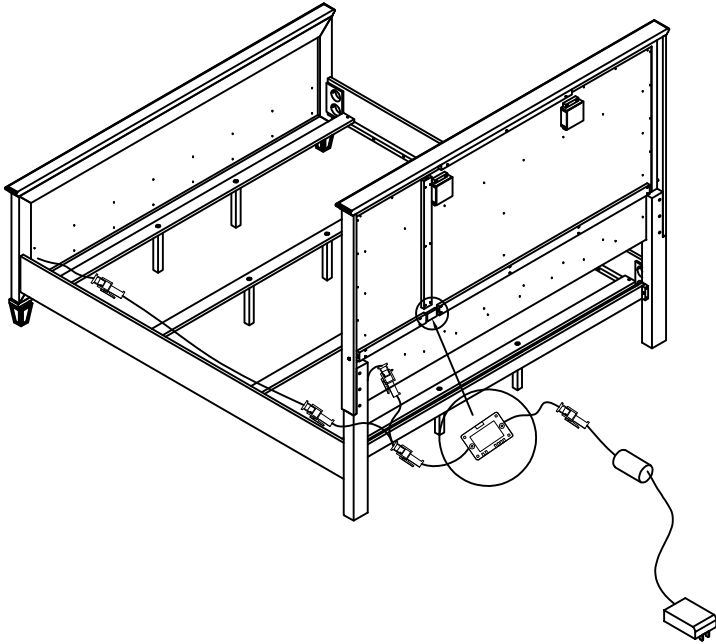

BLUETOOTH AND CONNECTIVITY

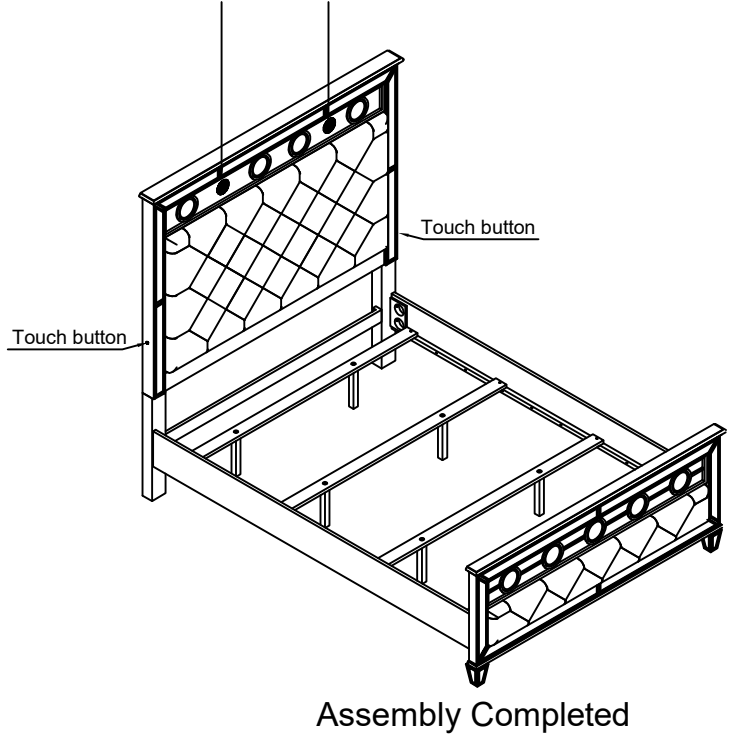

ASSEMBLED PRODUCT SPECIFICATIONS AND DIMENSIONS

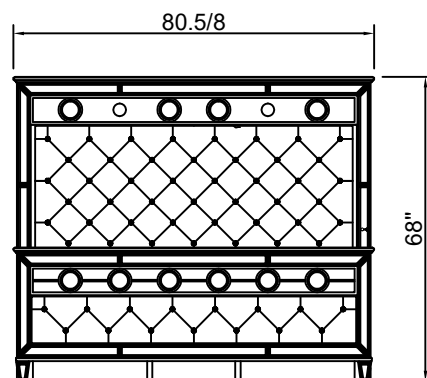
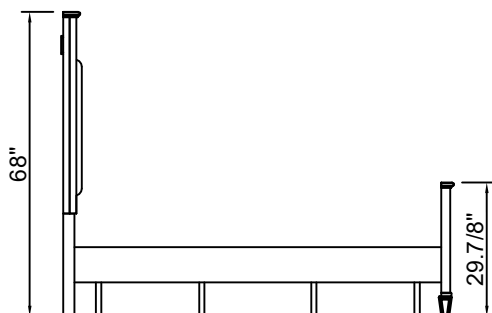
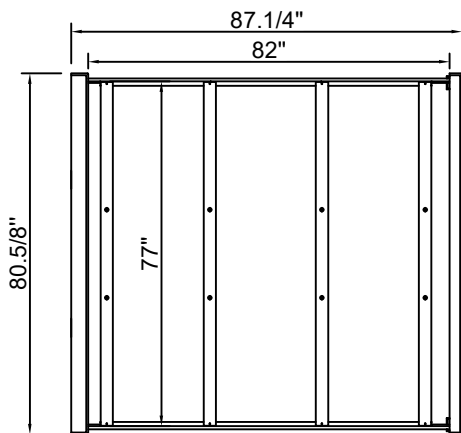

ASSEMBLY INSTRUCTIONS

ITEM NUMBER: GEMMA-KHB/KFB/Q/K RL
DESCRIPTION: KING BED

Caution: Please read instructions thoroughly before unpacking assembly parts. Sharp exposed staple tips can cause injury, therefore, for your protection, please remove any exposed staples used in packing.

- 1 We recommend that you should assemble this product with the assistance of another person; this will make assembly easier, and will help to eliminate damage to the product or injury to persons during assembly
 - 2 Be sure to check all packing materials carefully for small parts that may have come loose inside the carton during shipment.
 - 3 Please do not over tighten screws or bolts
 - 4 Please put all parts on a non-abrasive floor before assembly, and follow the assembly steps to assemble your newly purchased product correctly and efficiently
- . Do not allow children to climb on furniture.
 - . Do not place television sets on top of chest, door chest, and/or dressers.
 - . Please place heaviest objects in the lowest drawers.
 - . Please have no more than one drawer open at a time.