









ASSEMBLY INSTRUCTIONS

ITEM NUMBER: DALAL-WH-KB
DESCRIPTION: KING BED W/LED



Thank you for purchasing this quality product.
Please read instructions carefully prior to assembly.
Check carefully for small parts which may have come loose during transportation inside all the boxes.
Remove from boxes and place all parts and components on soft surface such as carpet, blanket or furniture pad. Identify and verify all parts and hardware as specified below.

Code	Hardware List For Headboard KING BED		Qty	Code	Hardware List For Footboard KING BED		Qty
①	JCBC Bolt (Ø5/16" x 50mm)		6pcs	⑧	Wood Screw #8*25mm		8pcs
	Sping washer (Ø5/16"x13x1.2)						
	Flat washer (Ø5/16"x19x2)						
②	JCBC Bolt (Ø1/4" x 38mm)		2pcs				
	Sping washer (Ø1/4"x13x1.2)						
	Flat washer (Ø1/4"x19x2)						
③	Allen Key (L60*4mm)		1pc	TOOLS REQUIRED (NOT PROVIDED) <hr/> Screwdriver 			
Hardware List For Rail							
④	Full thread bolt (Ø5/16"x75)		8pcs				
⑤	NUT washer (Ø5/16")		8pcs				
⑥	Corved Washer (Ø5/16")		8pcs				
⑦	Wrench key (1/2"x90mm)		1pc				

Assembly Tips:

- This assembly may require additional help (2 person set up)
- There is a tip restraint kit provided on the back of this product. please read the directions thoroughly an install immediately when placed in home

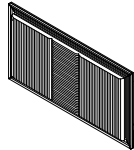
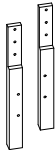
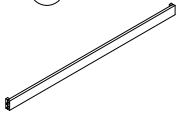
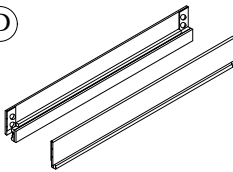
PARTS LIST

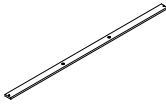
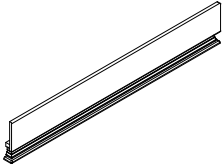
 Headboard Panel=1PC	 L/R Posts=2PCS	 Headboard Bottom Stretcher = 1PC	 Side Rails L/R=2PCS	 Long Support Leg for bed slats =8PCS
 Slats =4PCS	 Footboard =1PC			

ASSEMBLY INSTRUCTIONS
ITEM NUMBER: DALAL-WH-KB
DESCRIPTION: KING BED W/LED

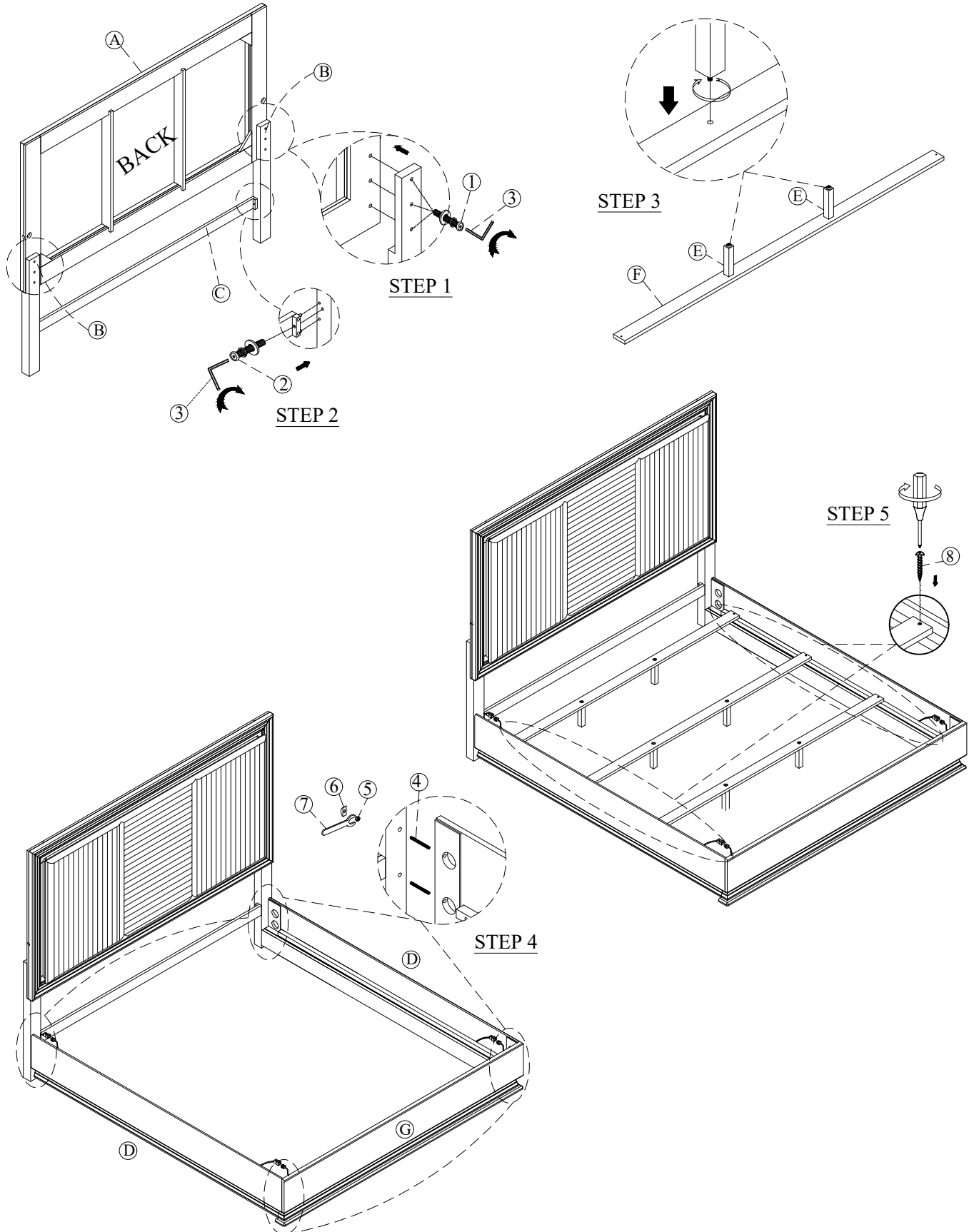

ADDITIONAL ASSEMBLY INFORMATION

ELECTRICAL CONNECTION DIAGRAM.

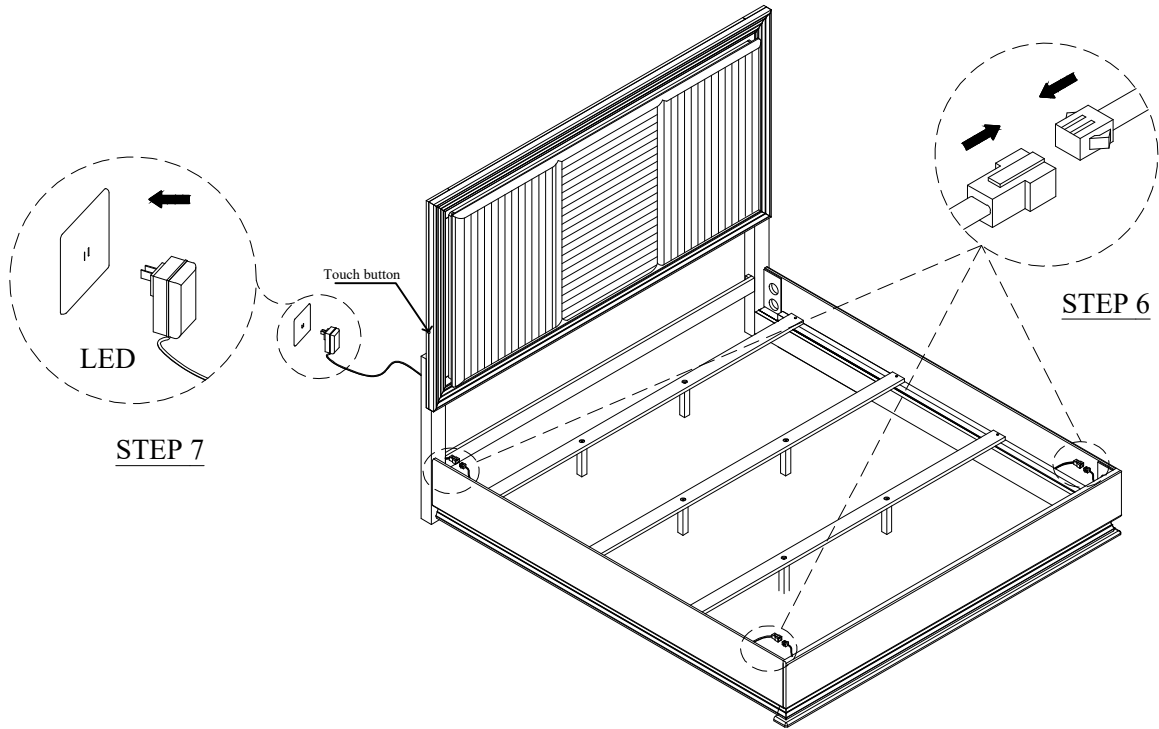

ADDITIONAL ASSEMBLY INFORMATION

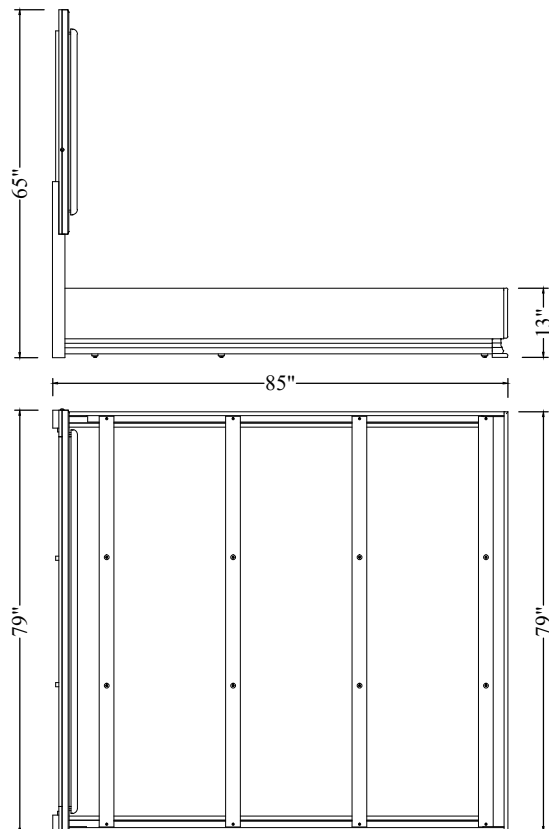



ASSEMBLY INSTRUCTIONS
ITEM NUMBER: DALAL-WH-KB
DESCRIPTION: KING BED W/LED

Caution: Please read instructions thoroughly before unpacking assembly parts. Sharp exposed staple tips can cause injury, therefore, for your protection, please remove any exposed staples used in packing.

- 1 We recommend that you should assemble this product with the assistance of another person; this will make assembly easier, and will help to eliminate damage to the product or injury to persons during assembly
 - 2 Be sure to check all packing materials carefully for small parts that may have come loose inside the carton during shipment.
 - 3 Please do not over tighten screw or bolts
 - 4 Please put all parts on a non-abrasive floor before assembly, and follow the assembly steps to assemble your newly purchased product correctly and efficiently
- . Do not allow children to climb on furniture.
 - . Do not place television sets on top of chest, door chest, and/or dressers.
 - . Please place heaviest objects on the lowest drawers.
 - . Please have no more than one drawer open at a time.