





ASSEMBLY INSTRUCTION

MODEL : BELLA DRESSER

(BOX 1) BOX OF DRESSER

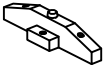
NO	ITEM	QTY
A	DRESSER 	1
B	METAL LEG 	4
C	CENTER LEG 	1

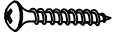
(BOX 1) HARDWARE LIST

NO	ITEM	QTY
1	Pan Head Screw  M3.5 x 16mm BLK	16
2	Flat Head Screw  M4 x 32mm RBW	4
3	Wood Dowel  Ø6 x 30mm	2

STEP 1

Pull the drawer and take out the Metal Leg carton (B).

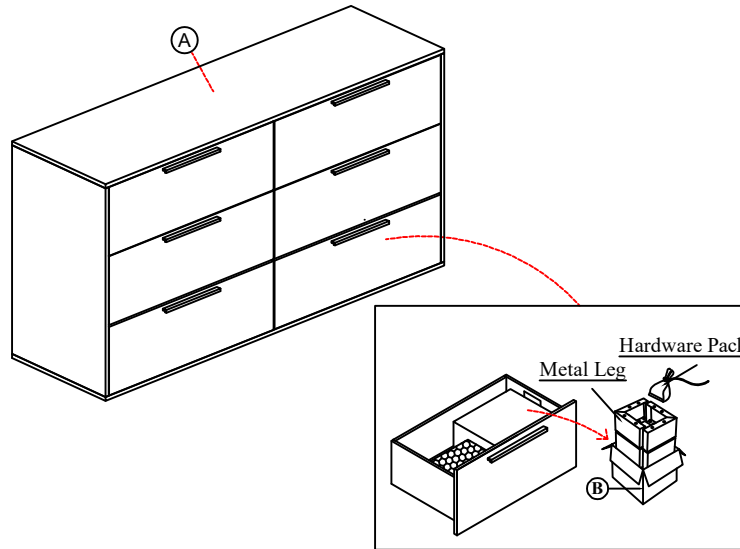

STEP 1

Place Metal Leg (B) On Marking Line. Fix using Pan Head Chipboard screw (1) and securing with Screw Driver (NOT PROVIDED) as shown

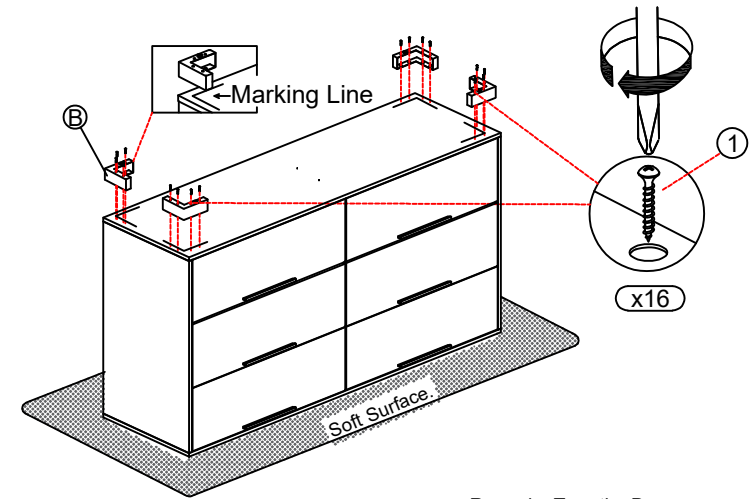

Remark : Turn the Dresser to upside down position as shown.

STEP 1

Assemble the Center Leg (C) with Flat Head Chipboard screw (2) and securing with Screw Driver (NOT PROVIDED) as shown.

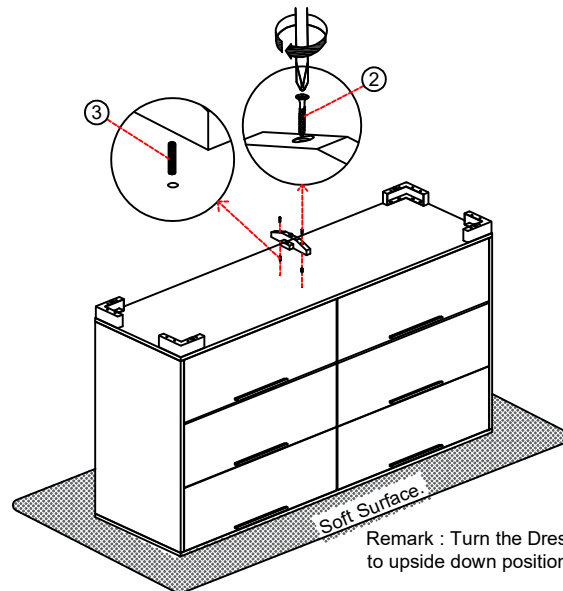

Remark : Turn the Dresser to upside down position as shown.

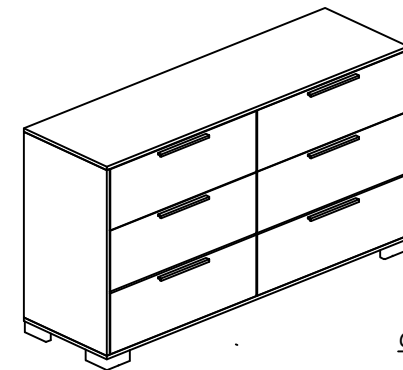

COMPLETED
ASSEMBLY

NOTE : MUST TIGHTEN SCREWS PERIODICALLY WITH USE SCREW WILL BECOME LOOSE.CHECK TIGHTNESS OF ALL SCREW EVERY 6-8 WEEKS.
DO NOT TIGHTEN BOLTS UNTIL COMPLETELY ASSEMBLED.