

















ASSEMBLY INSTRUCTIONS

ITEM NUMBER: BLISS-QHB/QFB/Q/K RL

DESCRIPTION: QUEEN BED

Thank you for purchasing this quality product.
Please read instructions carefully prior to assembly.







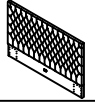
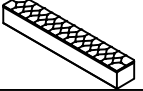

Check carefully for small parts which may have come loose during transportation inside all the boxes.
Remove from boxes and place all parts and components on soft surface such as carpet, blanket or furniture pad. Identify and verify all parts and hardware as specified below.

| Hardware List For Headboard-QHB | | | | | Hardware List For Side Rail - RL | | | | | Hardware List For Footboard-QFB | | | | |
|---------------------------------|-------------|---|------------|------|----------------------------------|------------------|---|-------------------|------|---|-------------|---|--------------|------|
| NO. | DESCRIPTION | OUTLOOK | SIZE | QTY. | NO. | DESCRIPTION | OUTLOOK | SIZE | QTY. | NO. | DESCRIPTION | OUTLOOK | SIZE | QTY. |
| 1 | Bolt |  | M8 x5/8" | 16 | 5 | Bolt |  | M6 x5/8" | 40 | 1 | Bolt |  | M8 x5/8" | 16 |
| 2 | Allen Key |  | M8 x2.1/2" | 1 | 6 | L - Bracket |  | 13/16"x11/16" | 8 | 2 | Allen Key |  | M8 x2.1/2" | 1 |
| 3 | USB Adapter |  | 2" | 1 | 7 | Angle Bracket -R |  | 1.13/16"x5.15/16" | 3 | 9 | Allen Key |  | M6 x2.3/8" | 1 |
| 4 | Cable |  | 59" | 1 | 8 | Angle Bracket -L |  | 1.13/16"x5.15/16" | 3 | 10 | Bolt |  | M6 x 1.3/4" | 3 |
| | | | | | 9 | Allen Key |  | M6 x2.3/8" | 1 | 11 | Base Glide |  | 7/8"x 1" | 3 |
| | | | | | | | | | | 12 | Wood Screw |  | 1/6"x 1.1/8" | 24 |
| DESCRIPTION | | | | | Tools Required (not provided) | | | | | Outlook | | | | |
| PHILLIPS SCREWDRIVER | | | | | | | | | |  | | | | |

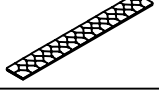
Assembly Tips:

- Place headboard upside down
- Do not tighten screws and bolts until final steps of the assembly
- This assembly may require additional help (2 person set up)

PART LIST

| NO. | DESCRIPTION | OUTLOOK | SIZE | QTY. |
|-----------|------------------|---|-----------------------------|-----------|
| A. | HEADBOARD |  | 86.1/4" X 61.1/16" X 4" | 1 |
| B. | FOOTBOARD |  | 86.1/4" X 14.6/8" X 13" | 1 |
| C. | SIDE PANEL |  | 81" X 11.13/16" X 9/16" | 4 |
| D. | SIDE CUSHION |  | 81" X 12.9/16" X 6/8" | 2 |
| E. | SIDE PATITION |  | 11.3/8" X 11.3/8" X 1/2" | 2 |
| F. | SIDE BOTTOM |  | 81" X 11.6/8" X 1/16" | 2 |
| G. | SLAT |  | 60.5/8" X 2.1/16" X 1/2" | 12 |
| H. | CENTER WOOD BASE |  | 80.6/8" X 1.3/16" X 1.3/16" | 1 |
| I. | Support Leg |  | 7.1/2" X 1.3/16" X 1.3/16" | 3 |

ASSEMBLY INSTRUCTIONS

ITEM NUMBER: BLISS-QHB/QFB/Q/K RL
DESCRIPTION: QUEEN BED

Thank you for purchasing this quality product.

Please read instructions carefully prior to assembly.

Check carefully for small parts which may have come loose during transportation inside all the boxes. Remove from boxes and place all parts and components on soft surface such as carpet, blanket or furniture pad. Identify and verify all parts and hardware as specified below.

STEP 1

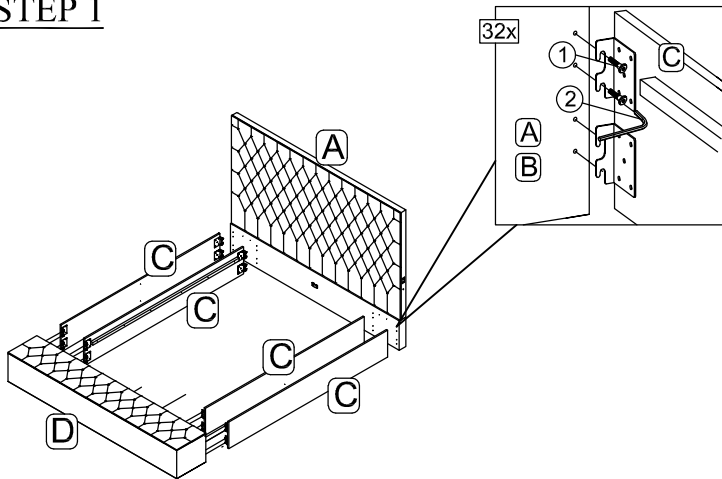

STEP 4

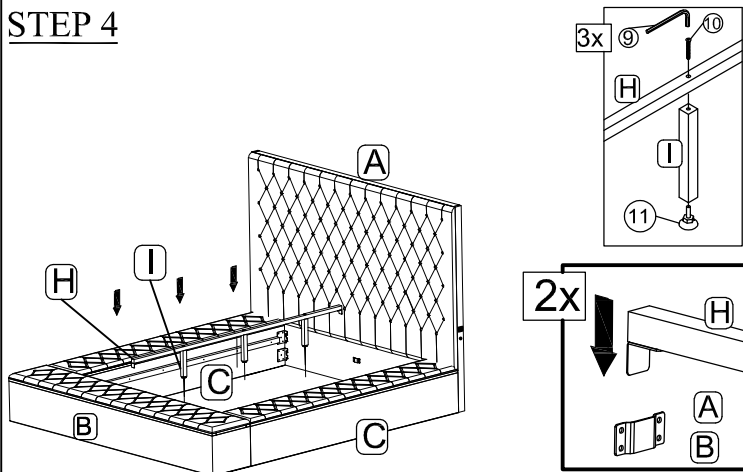

STEP 2

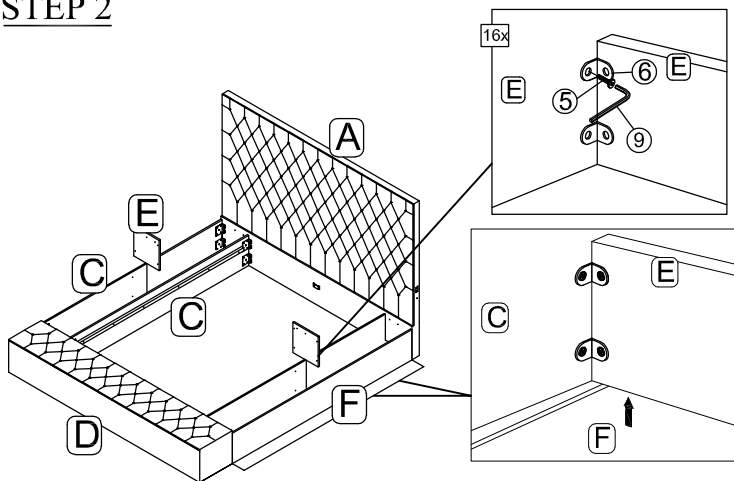

STEP 5

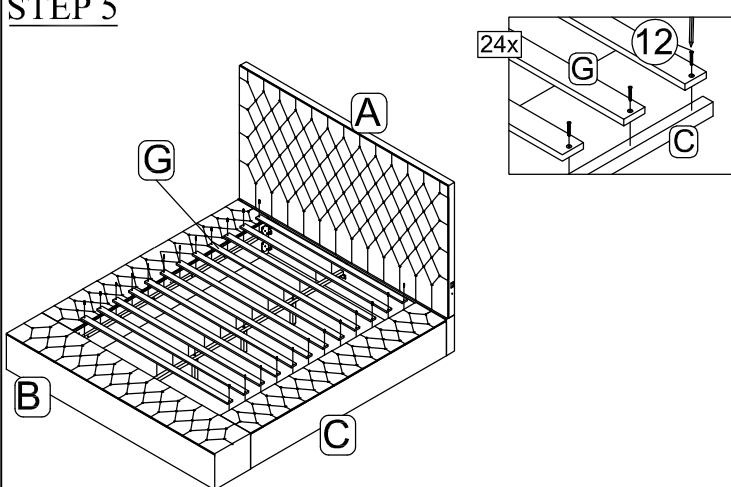

STEP 3

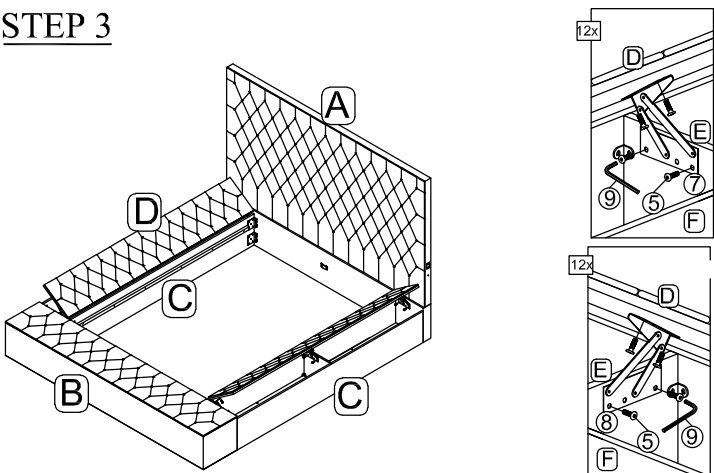

ASSEMBLY INSTRUCTIONS

ITEM NUMBER: BLISS-QHB/QFB/Q/K RL
 DESCRIPTION: QUEEN BED

ADDITIONAL ASSEMBLY INFORMATION

BLUETOOTH AND CONNECTIVITY

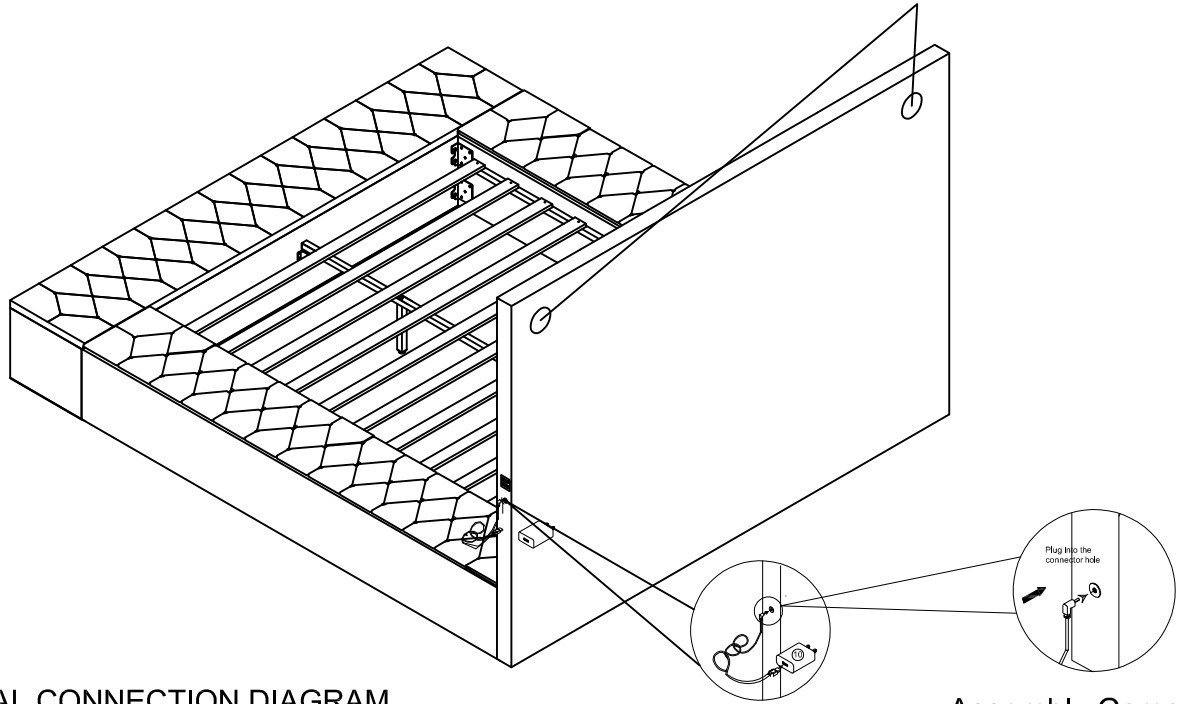

ELECTRICAL CONNECTION DIAGRAM.

Assembly Completed

ASSEMBLED PRODUCT SPECIFICATIONS AND DIMENSIONS

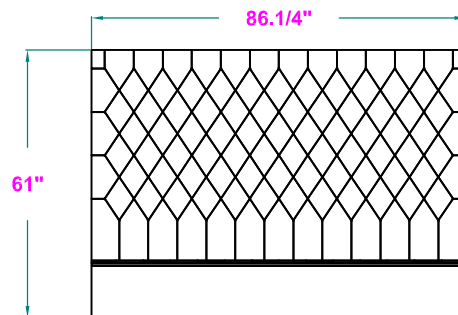
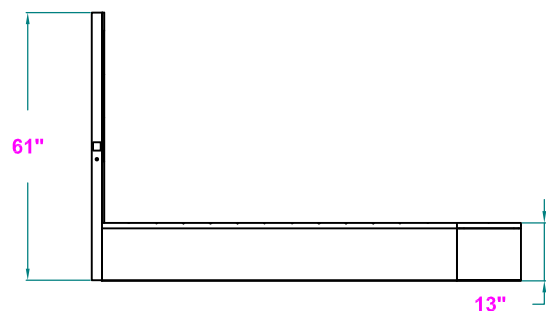
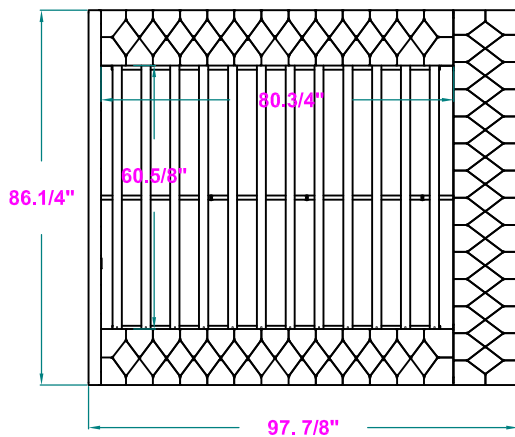



ASSEMBLY INSTRUCTIONS

ITEM NUMBER: BLISS-QHB/QFB/Q/K RL
DESCRIPTION: QUEEN BED

Caution: Please read instructions thoroughly before unpacking assembly parts. Sharp exposed staple tips can cause injury, therefore, for your protection, please remove any exposed staples used in packing.

- 1 We recommend that you should assemble this product with the assistance of another person; this will make assembly easier, and will help to eliminate damage to the product or injury to persons during assembly
 - 2 Be sure to check all packing materials carefully for small parts that may have come loose inside the carton during shipment.
 - 3 Please do not over-tighten screws or bolts
 - 4 Please put all parts on a non-abrasive floor before assembly, and follow the assembly steps to assemble your newly purchased product correctly and efficiently
- . Do not allow children to climb on furniture.
 - . Do not place television sets on top of chest, door chest, and/or dressers.
 - . Please place heaviest objects on the lowest drawers.
 - . Please have no more than one drawer open at a time.