

















# ASSEMBLY INSTRUCTIONS

## ITEM NUMBER: BLISS-KHB/KFB/Q/K RL

### DESCRIPTION: KING BED

Thank you for purchasing this quality product.  
Please read instructions carefully prior to assembly.







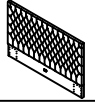
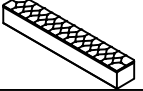

Check carefully for small parts which may have come loose during transportation inside all the boxes.  
Remove from boxes and place all parts and components on soft surface such as carpet, blanket or furniture pad. Identify and verify all parts and hardware as specified below.

Hardware List For Headboard-KHB					Hardware List For Side Rail - RL					Hardware List For Footboard-KFB				
NO.	DESCRIPTION	OUTLOOK	SIZE	QTY.	NO.	DESCRIPTION	OUTLOOK	SIZE	QTY.	NO.	DESCRIPTION	OUTLOOK	SIZE	QTY.
1	Bolt		M8 x5/8"	16	5	Bolt		M6 x5/8"	40	1	Bolt		M8 x5/8"	16
2	Allen Key		M8 x2.1/2"	1	6	L - Bracket		13/16"x11/16"	8	2	Allen Key		M8 x2.1/2"	1
3	USB Adapter		2"	1	7	Angle Bracket -R		1.13/16"x5.15/16"	3	9	Allen Key		M6 x2.3/8"	1
4	Cable		59"	1	8	Angle Bracket -L		1.13/16"x5.15/16"	3	10	Bolt		M6 x 1.3/4"	6
					9	Allen Key		M6 x2.3/8"	1	11	Base Glide		7/8"x 1"	6
										12	Wood Screw		1/6"x 1.1/8"	24
DESCRIPTION					Tools Required (not provided)					Outlook				
PHILLIPS SCREWDRIVER														

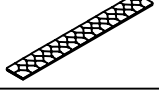
#### Assembly Tips:

- Place headboard upside down
- Do not tighten screws and bolts until final steps of the assembly
- This assembly may require additional help (2 person set up)

#### PART LIST

NO.	DESCRIPTION	OUTLOOK	SIZE	QTY.
<b>A.</b>	HEADBOARD		96.1/4" X 61.1/16" X 4"	1
<b>B.</b>	FOOTBOARD		96.1/4" X 14.6/8" X 13"	1
<b>C.</b>	SIDE PANEL		81" X 11.13/16" X 9/16"	4
<b>D.</b>	SIDE CUSHION		81" X 9.15/16" X 6/8"	2
<b>E.</b>	SIDE PATITION		11.3/8" X 8.5/8" X 1/2"	2
<b>F.</b>	SIDE BOTTOM		81" X 9.15/16" X 1/16"	2
<b>G.</b>	SLAT		76.3/8" X 2.1/16" X 1/2"	12
<b>H.</b>	CENTER WOOD BASE		80.6/8" X 1.3/16" X 1.3/16"	2
<b>I.</b>	Support Leg		7.1/2" X 1.3/16" X 1.3/16"	6

# ASSEMBLY INSTRUCTIONS

ITEM NUMBER: BLISS-KHB/KFB/Q/K RL  
DESCRIPTION: KING BED

Thank you for purchasing this quality product.

Please read instructions carefully prior to assembly.

Check carefully for small parts which may have come loose during transportation inside all the boxes. Remove from boxes and place all parts and components on soft surface such as carpet, blanket or furniture pad. Identify and verify all parts and hardware as specified below.

## STEP 1

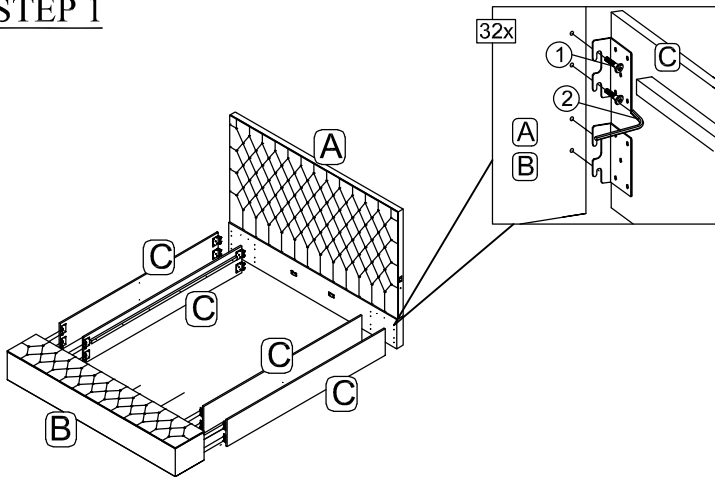

## STEP 4

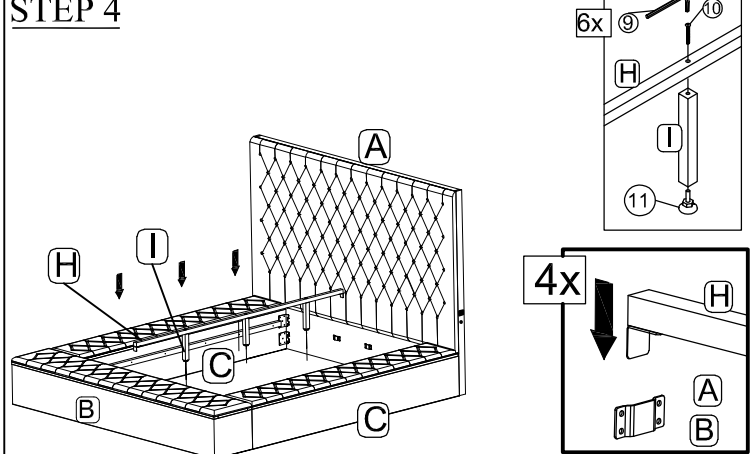

## STEP 2

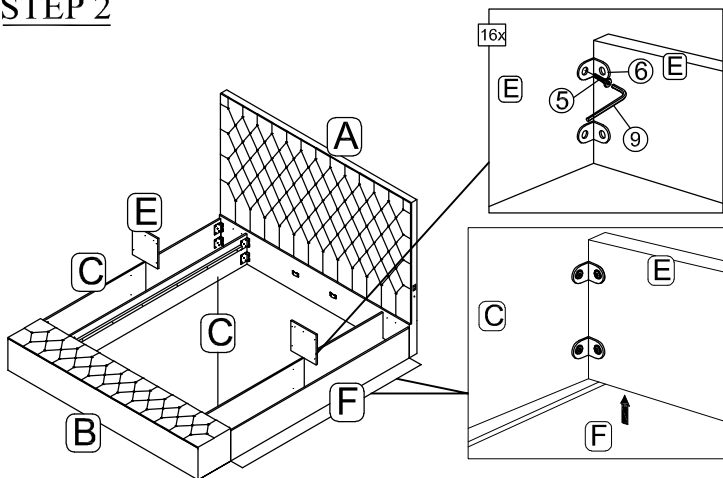

## STEP 5

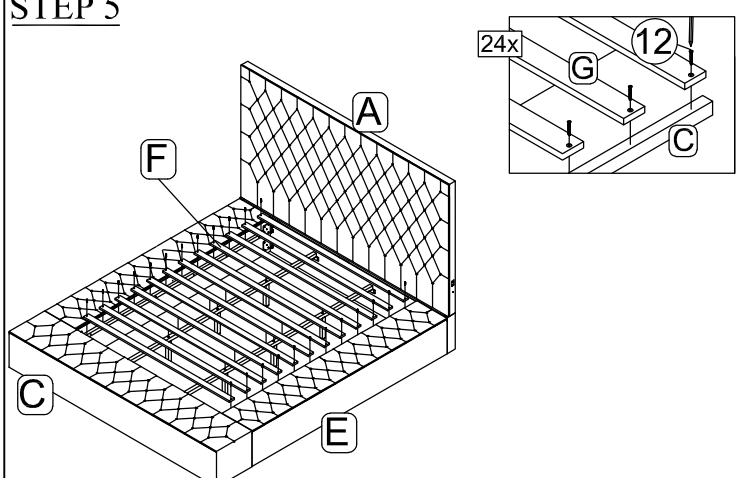

## STEP 3

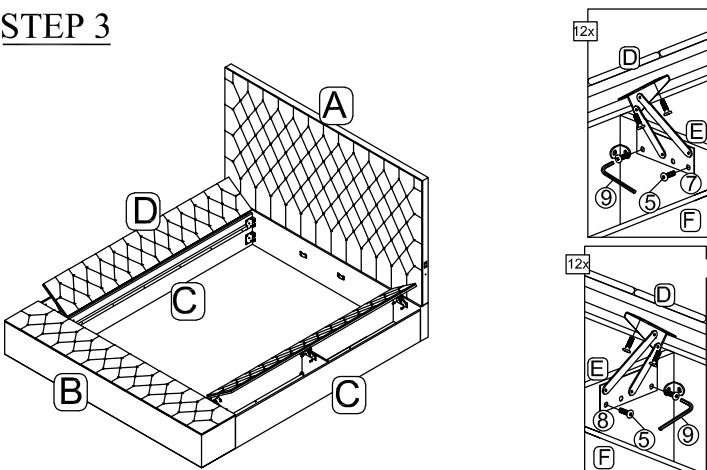

# ASSEMBLY INSTRUCTIONS

ITEM NUMBER: BLISS-KHB/KFB/Q/K RL  
 DESCRIPTION: KING BED

## ADDITIONAL ASSEMBLY INFORMATION

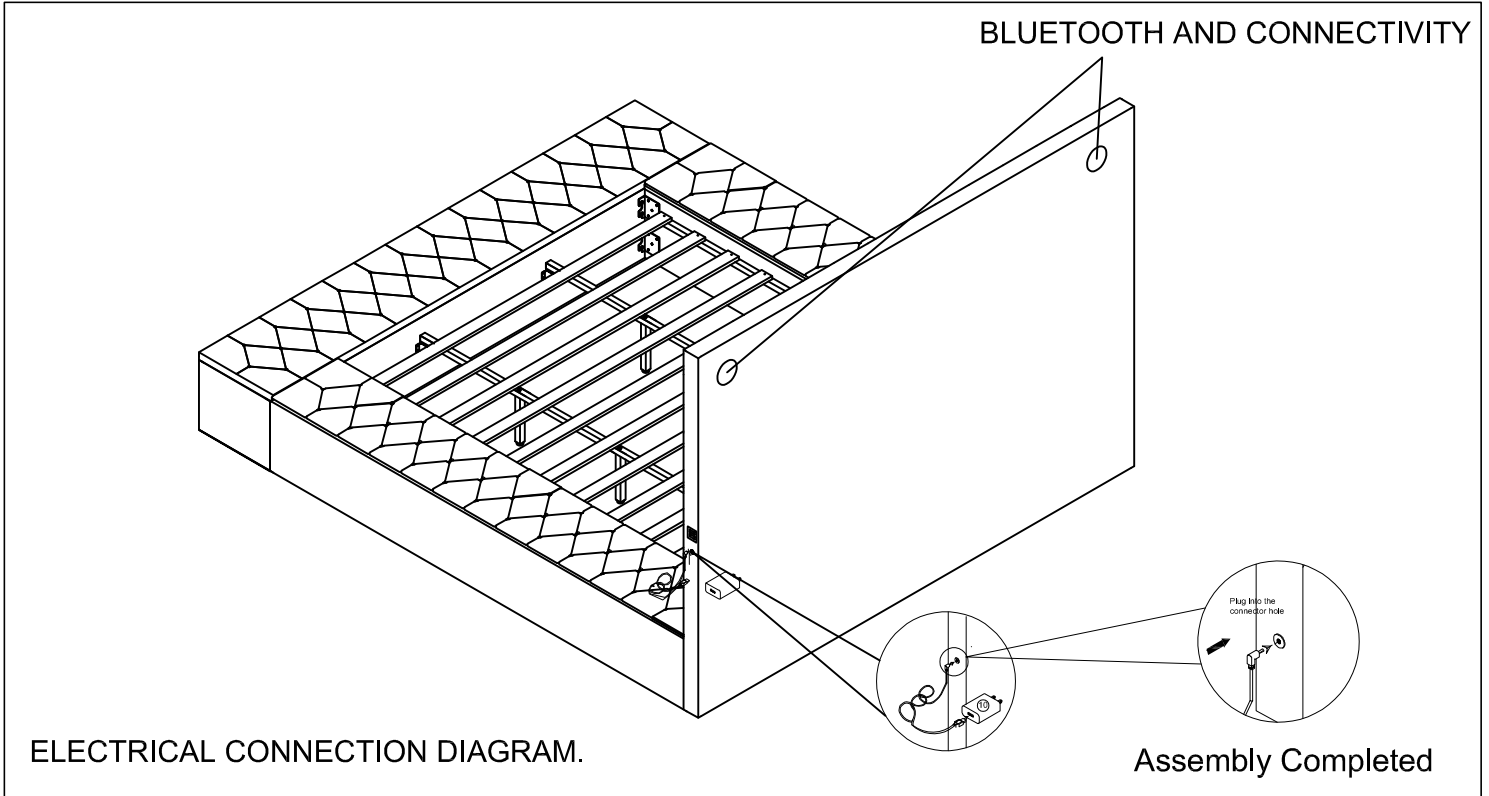

## ASSEMBLED PRODUCT SPECIFICATIONS AND DIMENSIONS

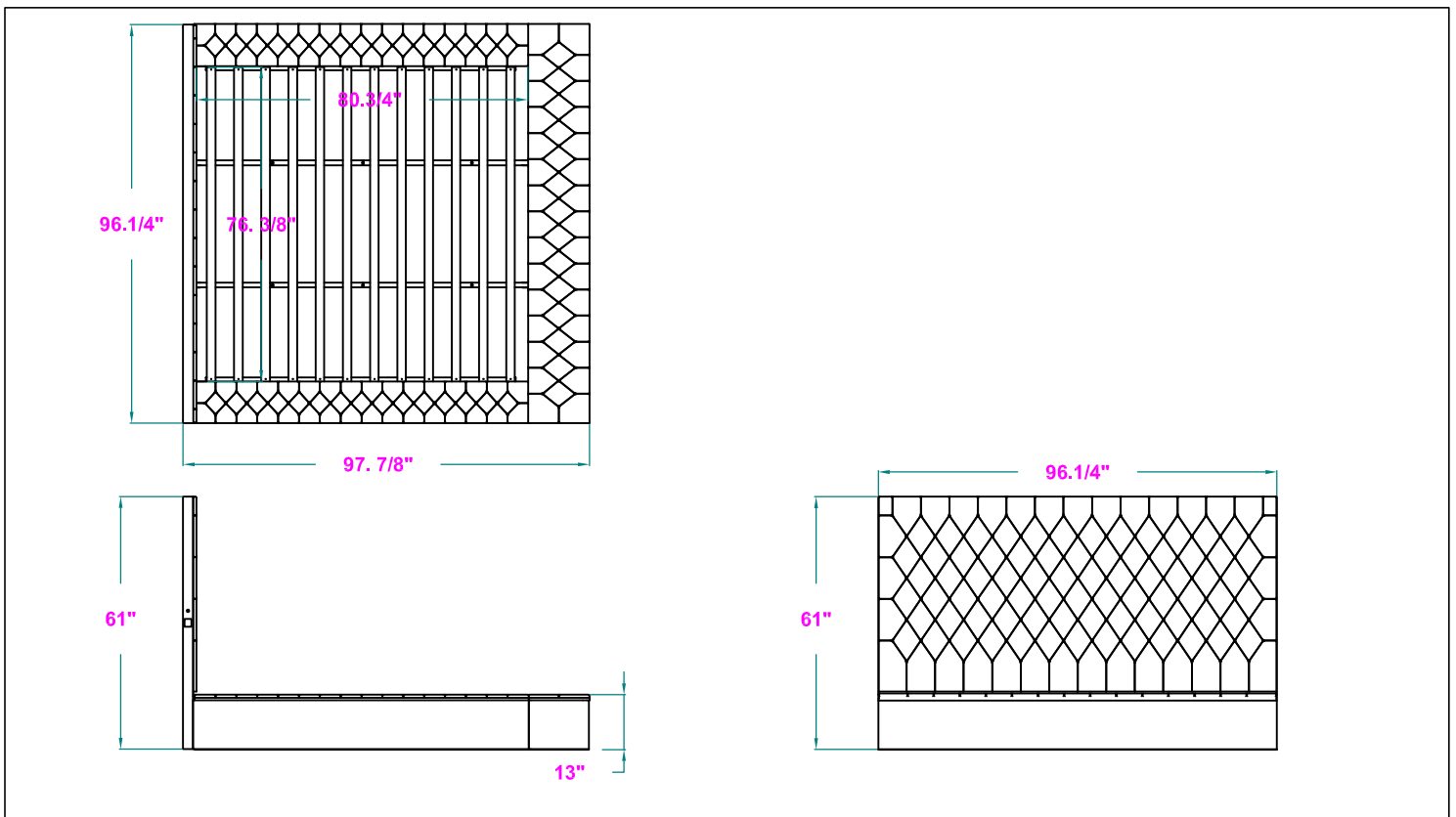



# ASSEMBLY INSTRUCTIONS

ITEM NUMBER: BLISS-KHB/KFB/Q/K RL  
DESCRIPTION: KING BED

**Caution:** Please read instructions thoroughly before unpacking assembly parts. Sharp exposed staple tips can cause injury, therefore, for your protection, please remove any exposed staples used in packing.

- 1 We recommend that you should assemble this product with the assistance of another person; this will make assembly easier, and will help to eliminate damage to the product or injury to persons during assembly
  - 2 Be sure to check all packing materials carefully for small parts that may have come loose inside the carton during shipment.
  - 3 Please do not over-tighten screws or bolts
  - 4 Please put all parts on a non-abrasive floor before assembly, and follow the assembly steps to assemble your newly purchased product correctly and efficiently
- . Do not allow children to climb on furniture.
  - . Do not place television sets on top of chest, door chest, and/or dressers.
  - . Please place heaviest objects on the lowest drawers.
  - . Please have no more than one drawer open at a time.