

# ASSEMBLY INSTRUCTIONS FOR

## GROUP NO : ABBY FHB/FFB & ABBY F/T RL

### DESCRIPTION : KING HEADBOARD & KING FOOTBOARD SLATS/V.LEGS & QUEEN/KING RAIL

#### STEP 1

#### BACK VIEW

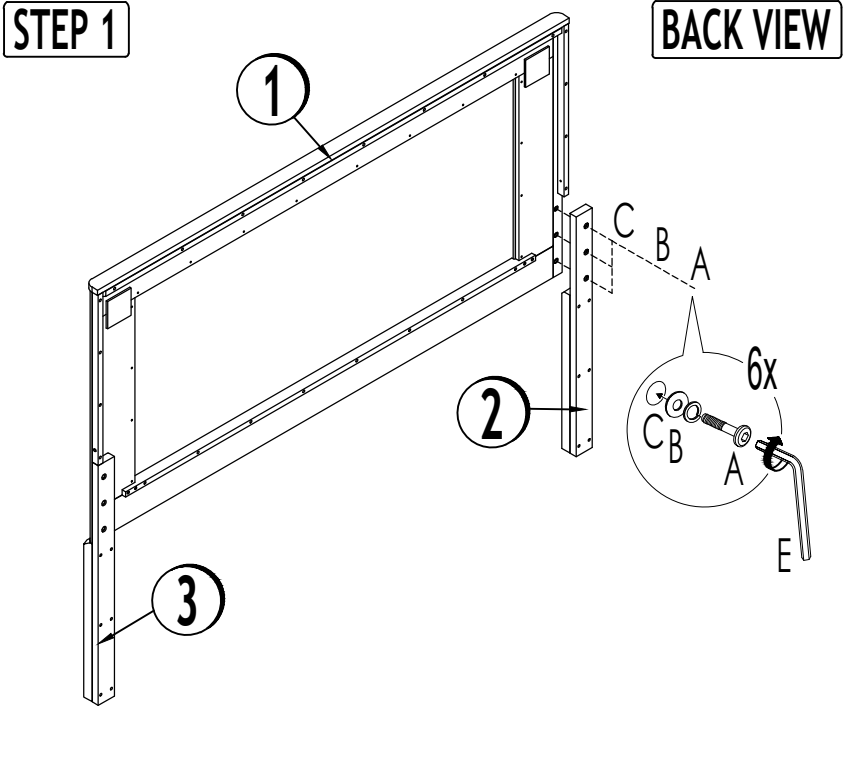

#### STEP 2

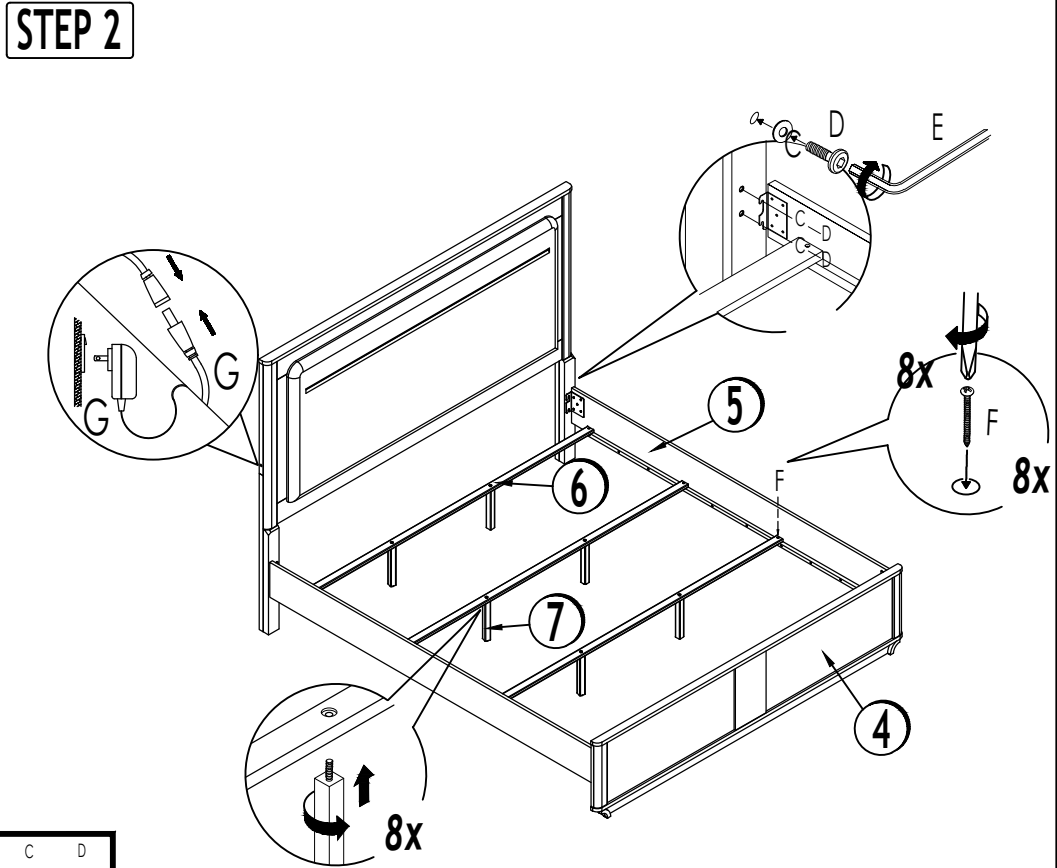

#### PARTS LIST

| NO | DESCRIPTION       | QTY    |
|----|-------------------|--------|
| 1  | HEADBOARD         | 1 PC.  |
| 2  | HEADBOARD LEG (L) | 1 PC.  |
| 3  | HEADBOARD LEG (R) | 1 PC.  |
| 4  | FOOTBOARD         | 1 PC.  |
| 5  | SIDE RAIL         | 2 PCS. |
| 6  | SLAT              | 4 PCS. |
| 7  | VERTICAL LEG      | 8 PCS. |

#### HARDWARE LIST

| NO | DESCRIPTION   | SIZE      | QTY     |
|----|---------------|-----------|---------|
| A  | JCBB          | M8 x 40MM | 6 PCS.  |
| B  | SPRING WASHER | M8        | 6 PCS.  |
| C  | FLAT WASHER   | M8 x 18MM | 14 PCS. |
| D  | JCBB          | M8 x 20MM | 8 PCS.  |
| E  | ALLEN KEY     | M5        | 1 PC.   |
| F  | PANHEAD       | M4 x 30MM | 8 PCS.  |
| G  | ADAPTER       |           | 1 PC.   |

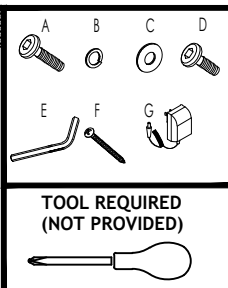

#### IMPORTANT NOTE :

- \* Place all wooden parts on a clean and smooth surface such as a rug or carpet to avoid the parts from being scratched.
- \* Check to be sure that you have all parts and hardware.
- \* Remove all wrapping materials, including staples & packing straps before you start to assemble.
- \* Do not tighten all screws/bolts until all completely assembled.
- \* Keep all hardware parts out of reach of children.